

**Programming Guide
GPIB DC Power Supplies
Agilent Technologies Models
664xA, 665xA, 667xA and 668xA**



Agilent Technologies

Safety Guidelines

The beginning of the power supply Operating Manual has a Safety Summary page. Be sure you are familiar with the information on that page before programming the power supply for operation from a controller.

WARNING

ENERGY HAZARD. Power supplies with high output currents (such as the Series 668xA) can provide more than 240 VA at more than 2 V. If the output connections touch, severe arcing may occur resulting in burns, ignition or welding of parts. Take proper precautions before remotely programming the output circuits.

Printing History

The edition and current revision of this guide are indicated below. Reprints of this guide containing minor corrections and updates may have the same printing date. Revised editions are identified by a new printing date. A revised edition incorporates all new or corrected material since the previous printing. Changes to the guide occurring between revisions are covered by change sheets shipped with the guide.

Edition 1..... November, 1993
..... October, 1997
..... April, 2000

© Copyright 1993 Agilent Technologies Inc.

This document contains proprietary information protected by copyright. All rights are reserved. No part of this document may be photocopied, reproduced, or translated into another language without the prior consent of Agilent Technologies.

The information contained in this document is subject to change without notice.

Contents

1.	Introduction	
	About this Guide	7
	Documentation Summary	7
	User's Guide.....	7
	External Documents	7
	Prerequisites for Using this Guide.....	8
	VXIplug&play Power Products Instrument Drivers.....	8
	Downloading and Installing the Driver	8
	Accessng Online Help	8
2.	Remote Programming	
	GPIB Capabilities of the Power Supply	9
	Introduction to SCPI.....	9
	Conventions.....	9
	SCPI Messages.....	10
	Types of SCPI Commands	10
	Structure of a Message	10
	Parts of a SCPI Message	11
	Traversing the Command Tree	12
	Including Common Commands.....	14
	SCPI Queries	14
	Value Coupling.....	14
	SCPI Data Formats	14
	Examples	15
	Controlling Output	16
	Saving and Recalling States	17
	Writing to the Display	17
	Programming Status	17
	Programming the Digital I/O Port	18
	System Considerations	18
	The GPIB Address	18
	DOS Drivers	20
	Agilent BASIC Controllers	20
	Sample Program Code.....	20
3.	Language Dictionary	
	Introduction	25
	Parameters	25
	Related Commands.....	25
	Order of Presentation	25
	Common Commands	25
	Subsystem Commands.....	25
	Description of Common Commands	26
	*CLS.....	26
	*ESE.....	27
	*ESR?.....	27
	*IDN?	28
	*OPC	28
	*OPC?	29
	*OPT?	29
	*PSC.....	29
	*RCL.....	30

*RST	31
*SAV	31
*SRE	32
*STB?	32
*TRG	33
*TST?	33
*WAI	33
Description of Subsystem Commands	34
ABOR	34
CURR[:LEV]	35
CURR:TRIG	35
CURR:PROT:STAT	35
DIG:DATA[:VAL]	36
DISP[:WIND][:STAT]	36
DISP[:WIND]:MODE	37
DISP[:WIND]:TEXT	37
INIT:CONT	37
INIT[:IMM]	38
MEAS:CURR[:DC]?	38
MEAS:VOLT[:DC]?	38
OUTP[:STAT]	38
OUTP:PROT]	39
OUTP:PROT:DEL	39
OUTP:REL	39
OUTP:REL:POL	39
STAT:OPER?	40
STAT:OPER:COND?	40
STAT:OPER:ENAB	41
STAT:OPER:NTR	41
STAT:OPER:PTR	41
STAT:PRES	42
STAT:QUES?	42
STAT:QUES:COND?	42
STAT:QUES:ENAB	42
STAT:QUES:NTR	43
STAT:QUES:PTR	43
SYST:ERR?	43
SYST:LANG	44
SYST:VERS?	44
TRIG[:IMM]	45
TRIG:SOUR	45
VOLT[:LEV]	45
VOLT:TRIG	45
VOLT:PROT[:LEV]	46
Command Summary	46
Programming Parameters	48

4.

Status Reporting

Power Supply Status Structure	49
Operation Status Group	49
Register Functions	49
Register Commands	49
Questionable Status Group	51
Register Functions	51
Register Commands	51

Standard Event Status Group.....	51
Register Functions	51
Register Commands.....	51
Status Byte Register	52
The RQS Bit	52
The MSS Bit.....	52
Determining the Cause of a Service Interrupt.....	52
Service Request Enable Register	52
Output Queue	52
Initial Conditions at Power-On.....	52
Status Registers	53
The PON (Power-On) Bit.....	53
Examples	53
Servicing an Operation Status Mode Event.....	53
Adding More Operation Events.....	54
Servicing Questionable Status Events	54
Monitoring Both Phases of a Status Transition	54
SCPI Command Completion	55
DFI (Discrete Fault Indicator)	55
RI (Remote Inhibit)	55
5. Error Messages	
Power Supply Hardware Error Messages	57
Calibration Error Messages	57
System Error Messages	57
A. SCPI Conformance Information	
SCPI Version.....	59
SCPI Confirmed Commands	59
SCPI Approved Commands.....	59
Non-SCPI Commands	60
B. Compatibility Language.....	61
Index.....	65

Figures

2-1. Command Message Structure.....	11
2-2. Partial Command Tree	13
3-1. Command Commands Syntax Diagram.....	26
3-2. Subsystem Commands Tree Diagram	34
4-1. Power Supply Status Model	50

Tables

2-1. Numerical Data Formats	15
2-2. Data Suffixes and Multipliers.....	15
2-3. Character Data Formats.....	15
3-1. SCPI Command Parameters	48
4-1. Status: Operation Commands.....	49
4-2. Bit Configuration of Status Registers.....	50
4-3. Status: Questionable Commands.....	51
4-4. Default Power-On Register States.....	53
4-5. Generating RQS from the CC Event	54
5-1. Summary of System Error Messages.....	57
B-1. ARPS Commands.....	62

Introduction

ABOUT THIS GUIDE

This guide provides remote programming information for the following series of GPIB programmable power supplies:

- AGILENT Series 664xA, 665xA, 667xA, and 668xA

You will find the following information in the rest of this guide:

Chapter 2	Introduction to SCPI messages structure, syntax, and data formats. Examples of SCPI programs.
Chapter 3	Dictionary of SCPI commands. Table of programming parameters.
Chapter 4	Description of the status registers.
Chapter 5	Error messages.
Appendix A	SCPI conformance information.
Appendix B	Use of the alternate Compatibility programming language.

DOCUMENTATION SUMMARY

User's Guide

The Operating Guide, shipped with the power supply, has information helpful to programming the power supply and explains the SCPI commands used for remote calibration. Sample calibration and verification programs are included.

External Documents

SCPI References

The following documents will assist you with programming in SCPI:

- *Standard Commands for Programmable Instruments Volume 1, Syntax and Style*
- *Standard Commands for Programmable Instruments Volume 2, Command References*
- *Standard Commands for Programmable Instruments Volume 3, Data Interchange Format*
- *Standard Commands for Programmable Instruments Volume 4, Instrument Classes*

To obtain a copy of the above documents, contact: Fred Bode, Executive Director, SCPI Consortium, 8380 Hercules Drive, Suite P3, Ls Mesa, CA 91942, USA

GPIB References

The most important GPIB documents are your controller programming manuals - Agilent BASIC, GPIB Command Library for MS DOS, etc. Refer to these for all non-SCPI commands (for example: Local Lockout).

The following are two formal documents concerning the GPIB interface:

- *ANSI/IEEE Std. 488.1-1987 IEEE Standard Digital Interface for Programmable Instrumentation* . Defines the technical details of the GPIB interface. While much of the information is beyond the need of most programmers, it can serve to clarify terms used in this guide and in related documents.
- *ANSI/IEEE Std. 488.2-1987 IEEE Standard Codes, Formats, Protocols, and Common Commands* . Recommended as a reference only if you intend to do fairly sophisticated programming. Helpful for finding precise definitions of certain types of SCPI message formats, data types, or common commands.

The previous two documents are available from the IEEE (Institute of Electrical and Electronics Engineers), 345 East 47th Street, New York, NY 10017, USA. The WEB address is www.ieee.org.

PREREQUISITES FOR USING THIS GUIDE

This organization of this guide assumes that you know or can learn the following information:

1. How to program in your controller language (Agilent BASIC, QUICKBASIC, C, etc.).
2. The basics of the GPIB (IEEE 488).
3. How to program I/O statements for an IEEE 488 bus instrument. From a programming aspect, the power supply is simply a bus instrument.
4. How to format ASCII statements within you I/O programming statements. SCPI commands are nothing more than ASCII data strings incorporated within those I/O statements.
5. The basic operating principles of the power supply as explained in “Chapter 5 – Front Panel Operation” of the Operating Guide.
6. How to set the GPIB address of the power supply. This cannot be done remotely, but only from the supply’s front panel (see System Considerations in “Chapter 2 – Remote Programming”).

VXIplug&play POWER PRODUCTS INSTRUMENT DRIVERS

VXIplug&play instrument drivers for Microsoft Windows 95 and Windows NT are now available on the Web at <http://www.agilent.com/find/drivers>. These instrument drivers provide a high-level programming interface to your Agilent Technologies instrument. VXIplug&play instrument drivers are an alternative to programming your instrument with SCPI command strings. Because the instrument driver's function calls work together on top of the VISA I/O library, a single instrument driver can be used with multiple application environments.

Supported Applications

- Agilent VEE
- Microsoft Visual BASIC
- Microsoft Visual C/C++
- Borland C/C++
- National Instruments LabVIEW
- National Instruments LabWindows/CVI

System Requirements

The VXIplug&play Power Products instrument driver complies with the following:

- Microsoft Windows 95
- Microsoft Windows NT
- HP VISA revision F.01.02
- National Instruments VISA 1.1

Downloading and Installing the Driver

NOTE: Before installing the VXIplug&play instrument driver, make sure that you have one of the supported applications installed and running on your computer.

1. Access Agilent Technologies' Web site at <http://www.agilent.com/find/drivers>.
2. Select the instrument for which you need the driver.
3. Click on the driver, either Windows 95 or Windows NT, and download the executable file to your pc.
4. Locate the file that you downloaded from the Web. From the **Start** menu select **Run** <path>:\agxxxx.exe - where <path> is the directory path where the file is located, and agxxxx is the instrument driver that you downloaded .
5. Follow the directions on the screen to install the software. The default installation selections will work in most cases. The readme.txt file contains product updates or corrections that are not documented in the on-line help. If you decide to install this file, use any text editor to open and read it.
6. To use the VXIplug&play instrument driver, follow the directions in the VXIplug&play online help under “Introduction to Programming”.

Accessing Online Help

A comprehensive online programming reference is provided with the driver. It describes how to get started using the instrument driver with Agilent VEE, LabVIEW, and LabWindows. It includes complete descriptions of all function calls as well as example programs in C/C++ and Visual BASIC.

- To access the online help when you have chosen the default Vxipnp start folder, click on the Start button and select Programs | Vxipnp | Agxxxx Help (32-bit).
- where agxxxx is the instrument driver.

Remote Programming

GPIB Capabilities Of The Power Supply

All power supply functions except for setting the GPIB address are programmable over the IEEE 488 bus (also known as the General Purpose Interface Bus or "GPIB"). The IEEE 488.1 capabilities of the power supply are listed in the Supplemental Characteristics of the Operating Guide. The power supply operates from a GPIB address that is set from the front panel (see **System Considerations** at the end of this chapter).

Introduction To SCPI

Important Learn the basics of power supply operation (see "Chapter 5 - Front Panel Operation" in the power supply Operating Guide) before using SCPI.

SCPI (Standard Commands for Programmable Instruments) is a programming language for controlling instrument functions over the GPIB (IEEE 488) instrument bus. SCPI is intended to function with standard GPIB hardware and conforms to the IEEE Standard Digital Interface for Programmable Instrumentation. SCPI is layered on top of the hardware portion of IEEE 488.2. The same SCPI commands and parameters control the same functions in different classes of instruments. For example, you would use the same DISPLAY command to control the power supply display state and the display state of a SCPI-compatible multimeter.

Note HPSL and TMSL (Test and Measurement System Language) were earlier versions of SCPI. If you have programmed in either, then you probably can go directly to "Chapter 3 - Language Dictionary".

Conventions

The following conventions are used throughout this chapter:

Angle brackets	< >	Items within angle brackets are parameter abbreviations. For example, <NR1> indicates a specific form of numerical data.
Vertical bar		Vertical bars separate one of two or more alternative parameters. For example, 0 OFF indicates that you may enter either "0" or "OFF" for the required parameter.
Square Brackets	[]	Items within square brackets are optional. The representation [SOURCE]:CURRENT means that SOURCE may be omitted.
Braces	{ }	Braces indicate parameters that may be repeated zero or more times. It is used especially for showing arrays. The notation <A>{} shows that "A" is a required parameter, while "B" may be omitted or may be entered one or more times.
Boldface font		Boldface font is used to emphasize syntax in command definitions. TRIGger:DELay <NRf> shows a command syntax.
Computer font		Computer font is used to show program text within normal text. TRIGger:DELay .5 represents program text.

SCPI Messages

There are two types of SCPI messages, program and response.

- A *program message* consists of one or more properly formatted SCPI commands sent from the controller to the power supply. The message, which may be sent at any time, requests the power supply to perform some action.
- A *response message* consists of data in a specific SCPI format sent from the power supply to the controller. The power supply sends the message only when commanded by a special program message called a "query."

Types of SCPI Commands

SCPI has two types of commands, common and subsystem.

Common Commands

Common commands (see Figure 3-1) generally are not related to specific operation but to controlling overall power supply functions, such as reset, status, and synchronization. All common commands consist of a three-letter mnemonic preceded by an asterisk:

```
*RST *IDN? *SRE 8
```

Subsystem Commands

Subsystem commands (see Figure 3-2) perform specific power supply functions. They are organized into an inverted tree structure with the "root" at the top. Some are single commands while others are grouped under other subsystems.

Structure of a SCPI Message

SCPI messages consist of one or more message units ending in a message terminator. The terminator is not part of the syntax, but implicit in the way your programming language indicates the end of a line (such as a newline or end-of-line character).

The Message Unit

The simplest SCPI command is a single message unit consisting of a command header (or keyword) followed by a message terminator.

```
ABOR  
VOLT?
```

The message unit may include a parameter after the header. The parameter usually is numeric, but it can be a string:

```
VOLT 20  
VOLT MAX
```

Combining Message Units

The following command message (see Figure 2-1) is briefly described here, with more details in subsequent paragraphs.

```
VOLT:LEV 4.5;PROT 4.8;;CURR?<NL>
```

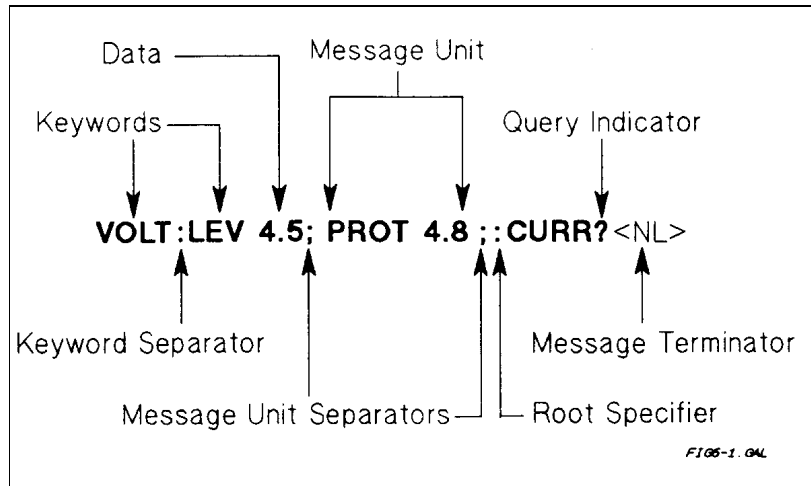

Figure 2-1. Command Message Structure

The basic parts of the message in Figure 2-1 are:

Message Component	Example
Headers	VOLT LEV PROT CURR
Header Separator	The colon in VOLT:LEV
Data	4.5 4.8
Data Separator	The space in VOLT 4.5 and PROT 4.8
Message Units	VOLT:LEV 4.5 PROT 4.8 CURR?
Message Unit Separator	The semicolons in VOLT:LEV 4.5; and PROT 4.8;
Root Specifier	The colon in PROT 4.8 ; CURR?
Query Indicator	The question mark in CURR?
Message Terminator	The <NL> (newline) indicator. Terminators are not part of the SCPI syntax.

Parts of a SCPI Message

Headers

Headers (which are sometimes known as "keywords") are instructions recognized by the power supply interface. Headers may be either in the long form or the short form.

- Long Form** The header is completely spelled out, such as **VOLTAGE STATUS DELAY**.
- Short Form** The header has only the first three or four letters, such as **VOLT STAT DEL**.

Short form headers are constructed according to the following rules:

- If the header consists of *four or fewer* letters, use all the letters. (**DFI DATA**)
- If the header consists of *five or more* letters and the fourth letter is not a vowel (a,e,i,o,u), use the first four letters. (**VOLTage STATus**)
- If the header consists of *five or more* letters and the fourth letter is a vowel (a,e,i,o,u), use the first three letters. (**DELay CLEAR**)

You must follow the above rules when entering headers. Creating an arbitrary form, such as **QUEST** for **QUESTIONABLE**, will result in an error. The SCPI interface is not sensitive to case. It will recognize any case mixture, such as **VOLTAGE**, **Voltage**, **Volt**, **volt**.

Note Shortform headers result in faster program execution.

Header Convention. In this manual, headers are emphasized with **boldface** type. The proper short form is shown in upper-case letters, such as **DElay**.

Header Separator. If a command has more than one header, you must separate them with a colon. (**VOLT:PROT OUTPut:PROTection:CLEar**)

Optional Headers. The use of some headers is optional. Optional headers are shown in brackets, such as **OUTPut[:STATe] ON**. However, if you combine two or more message units into a compound message, you may need to enter the optional header. This is explained under "Traversing the Command Tree."

Query Indicator

Following a header with a question mark turns it into a query (**VOLT? VOLT:PROT?**). If a query contains a parameter, place the query indicator at the end of the last header (**VOLT:PROT? MAX**).

Message Unit Separator

When two or more message units are combined into a compound message, separate the units with a semicolon (**STATus:OPERation?:QUEStionable?**).

Important

You can combine message units only at the current path of the command tree (see "Traversing the Command Tree").

Root Specifier

When it precedes the first header of a message unit, the colon becomes a "root specifier". This indicates that the command path is at the root or top node of the command tree. Note the difference between root specifiers and header separators in the following examples:

OUTP:PROT:DEL .1	All colons are header separators
OUTP:PROT:DEL .1	The first colon is a root specifier
OUTP:PROT:DEL .1;VOLT 12.5	The third colon is a root specifier

Message Terminator

A terminator informs SCPI that it has reached the end of a message. Three permitted messages terminators are:

- Newline (<NL>), which is ASCII decimal 10 or hex 0A.
- End or identify (<END>).
- Both of the above (<NL><END>).

In the examples of this manual, there is an assumed message terminator at the end of each message. If the terminator needs to be shown, it is indicated as <NL> regardless of the actual terminator character.

Traversing the Command Tree

Figure 2-2 shows a portion of the subsystem command tree (you can see the complete tree in Figure 3-2). Note the location of the ROOT node at the top of the tree. The SCPI interface is at this location when:

- The power supply is powered on.
- A device clear (DCL) is sent to the power supply.
- The interface encounters a message terminator.
- The interface encounters a root specifier.

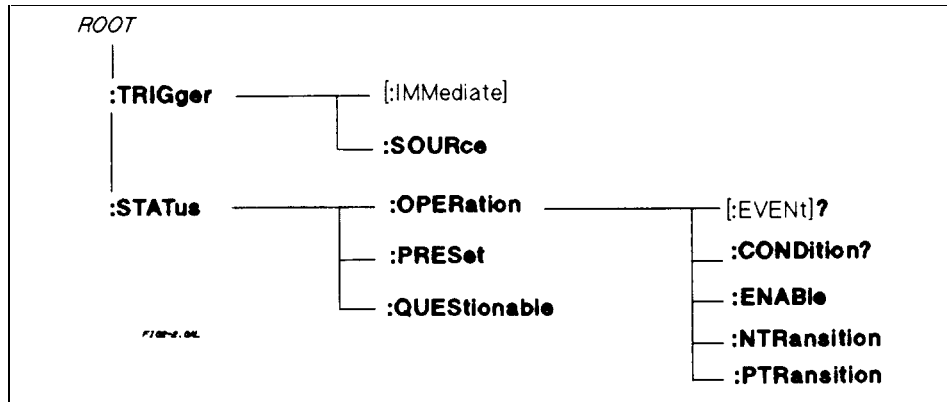

Figure 2-2. Partial Command Tree

Active Header Path

In order to properly traverse the command tree, you must understand the concept of the active header path. When the power supply is turned on (or under any of the other conditions listed above), the active path is at the root. That means the interface is ready to accept any command at the root level, such as **TRIGger** or **STATus** in Figure 2-2. Note that you do not have to precede either command with a colon; there is an implied colon in front of every root-level command.

If you enter **STATUS**, the active header path moves one colon to the right. The interface is now ready to accept **:OPERATION**, **:PRESet**, or **QUESTIONABLE** as the next header. Note that you must include the colon, because it is required between headers.

If you next enter **:OPERATION**, the active path again moves one colon to the right. The interface is now ready to accept **:EVENT?**, **CONDITON?**, **ENABLE**, **NTRANSITION**, or **PTRANSITION** as the next header.

If you now enter **:ENABLE**, you have reached the end of the command string. The active header path remains at **:ENABLE**. If you wished, you could have entered **:ENABLE 18;PTRANSITION 18** and it would be accepted. The entire message would be **STATUS:OPERATION:ENABLE 18;PTRANSITION 18**. The message terminator after **PTRANSITION 18** returns the path to the root.

The Effect of Optional Headers

If a command includes optional headers, the interface assumes they are there. For example, if you enter **STATUS:OPERATION?**, the interface recognizes it as **STATUS:OPERATION:EVENT?** (see Figure 2-2). This returns the active path to the root (**:STATUS**). But if you enter **STATUS:OPERATION:EVENT?**, then the active path remains at **:EVENT**. This allows you to send **STATUS:OPERATION:EVENT?;CONDITION?** in one message. If you tried to send **STATUS:OPERATION?;CONDITION?** the command path would send **STATUS:OPERATION:EVENT?** and then return to **:STATUS** instead of to **:CONDITION**.

The optional header **SOURCE** precedes the current, digital, and voltage subsystems (see Figure 3-2). This effectively makes **:CURRENT**, **:DIGITAL**, and **:VOLTAGE** root-level commands.

Moving Among Subsystems

In order to combine commands from different subsystems, you need to be able to restore the active path to the root. You do this with the root specifier (**:**). For example, you could clear the output protection and check the status of the Operation Condition register as follows (see Figure 3-2):

```

OUTPUT:PROTECTION:CLEAR
STATUS:OPERATION:CONDITION?
  
```

By using the root specifier, you could do the same thing in one message:

```

OUTPUT:PROTECTION:CLEAR::STATUS:OPERATION:CONDITION?
  
```

Note The SCPI parser traverses the command tree as described in Appendix A of the IEEE 488.2 standard. The "Enhanced Tree Walking Implementation" given in that appendix is *not* implemented in the power supply.

The following message shows how to combine commands from different subsystems as well as within the same subsystem (see Figure 3-2):

VOLTAGE:LEVEL 7;PROTECTION 8;;CURRENT:LEVEL 150;PROTECTION ON

Note the use of the optional header **LEVEL** to maintain the correct path within the voltage and current subsystems and the use of the root specifier to move between subsystems.

Including Common Commands

You can combine common commands with system commands in the same message. Treat the common command as a message unit by separating it with the message unit separator. Common commands *do not affect the active header path*; you may insert them anywhere in the message.

**VOLT:TRIG 7.5;INIT;*TRG
OUTP OFF;*RCL 2;OUTP ON**

SCPI Queries

Observe the following precautions with queries:

- Remember to set up the proper number of variables for the returned data.
- Set the program to read back all the results of a query before sending another command to the power supply. Otherwise, a *Query Interrupted* error will occur and the unreturned data will be lost.

Value Coupling

Value coupling results when a command directed to send one parameter also changes the value of a second parameter. There is no direct coupling among any power supply SCPI commands. However, be aware that until they are programmed, uninitialized trigger levels will assume their corresponding immediate levels. For example, if a power supply is powered up and **VOLT:LEV** is programmed to **6**, then **VOLT:LEV:TRIG** will also be **6** until you program it to another value. Once you program **VOLT:LEV:TRIG** to another value, it will remain at that value regardless of how you subsequently reprogram **VOLT:LEVEL**.

SCPI Data Formats

All data programmed to or returned from the power supply is ASCII. The data may be *numerical or character string*.

Numerical Data

Table 2-1 and Table 2-2 summarize the numerical formats.

Table 2-1. Numerical Data Formats

Symbol	Data Form
Talking Formats	
<NR1>	Digits with an implied decimal point assumed at the right of the least-significant digit. Examples: 273 0273
<NR2>	Digits with an explicit decimal point. Example: 273. .0273
<NR3>	Digits with an explicit decimal point and an exponent. Example: 2.73E+2 273.0E-2
Listening Formats	
<NRf>	Extended format that includes <NR1>, <NR2> and <NR3>. Examples: 273 273. 2.73E2

<NRf+>	Expanded decimal format that includes <NRf>, MIN and MAX . Examples: 273 273. 2.73E2 MAX . MIN and MAX are the minimum and maximum limit values that are implicit in the range specification for the parameter.
--------	--

Table 2-2. Suffixes and Multipliers

Class	Suffix	Unit	Unit with Multiplier
Current	A	Ampere	MA (milliampere)
Amplitude	V	Volt	MV (millivolt)
Time	S	second	MS (millisecond)
Common Multipliers			
	1E3	K	kilo
	1E-3	M	milli
	1E-6	U	micro

Boolean Data

Either form {1|0} or {ON|OFF} may be sent with commands. Queries always return 1 or 0.

OUTPut OFF
CURRent:PROTection 1

Character Data

For query statements, character strings may be returned in either of the forms shown in Table 2-3, depending on the length of the returned string.

Table 2-3. Character Data Formats

<CRD>	<u>Character Response Data</u> . Permits the return of character strings.
<AARD>	<u>Arbitrary ASCII Response Data</u> . Permits the return of undelimited 7-bit ASCII. This data type has an implied message terminator.
Note:	The IEEE 488.2 format for a string parameter requires that the string be enclosed within either single (' ') or double (" ") quotes. Be certain that your program statements comply with this requirement.

Examples

The examples given here are generic, without regard to the programming language or type of GPIB interface. Because SCPI commands are sent as ASCII output strings within the programming language statements, the SCPI syntax is independent of both programming language and interface.

Note The examples are followed by sample program code written for three popular types of BASIC-controlled GPIB interfaces.

Controlling Output

Important The power supply responds simultaneously to both digital and analog programming inputs. If it is receiving an input over the GPIB and a corresponding input from the front panel (and/or from the analog programming port), the power supply output will be the algebraic sum of the inputs.

Programming Voltage and Current

The following statements program both voltage and current and return the actual output from the sense terminals:

OUTP OFF	<i>Disable the output.</i>
VOLT 4.5;CURR 255	<i>Program the voltage and current.</i>
VOLT?;CURR?	<i>Read back the programmed levels.</i>
OUTP ON	<i>Enable the output.</i>
MEAS:VOLT?;MEAS:CURR?	<i>Read back the outputs from the sense terminals.</i>

Programming Protection Circuits

This example programs the voltage and current, programs an overvoltage protection value, and turns on the overcurrent protection. It then reads back all the programmed values.

VOLT:LEV 4.5;PROT 4.75	<i>Program the voltage and overvoltage protection.</i>
CURR:LEV 255;PROT:STAT ON	<i>Program the current and overcurrent protection.</i>
VOLT:LEV?;PROT?;CURR:LEV?;PROT:STAT?	<i>Read back the programmed values.</i>

Note the required use of the optional **LEVel** header in the above example (see "The Effect of Optional Headers", given previously).

Changing Outputs by Trigger

If you do not program pending triggered levels, they default to the programmed (immediate) output levels. The following statements shows some basic trigger commands.

OUTP OFF	<i>Disable the output.</i>
VOLT:LEV:IMM 2.2;TRIG 2.5	<i>Program the (immediate) voltage level to 2.2V and the pending triggered level to 2.5 V.</i>
CURR:LEV:IMM 150;TRIG 250	<i>Program the (immediate) current level to 150 A and the pending triggered level to 250 A.</i>
VOLT:LEV:IMM?;TRIG?;CURR:LEV:IMM?;TRIG?	<i>Check all the programmed values.</i>
OUTP ON	<i>Enable the output.</i>
MEAS:VOLT?;CURR?	<i>Read back the immediate levels from the sense terminals.</i>
INIT;TRIG	<i>Arm the trigger circuit and send a single trigger.</i>
INIT;*TRG	<i>Same as above, except using a common command.</i>
MEAS:VOLT?;CURR?	<i>Read back the triggered levels from the sense terminals.</i>

If you need to send two or more triggers, program the trigger circuit for continuous arming.

OUTP OFF	<i>Disable the output.</i>
VOLT:LEV:IMM 5.0;TRIG 2.5	<i>Program the (immediate) voltage level to 5 V and the pending triggered level to 2.5 V.</i>
INIT:CONT ON	<i>Program the trigger circuit for continuous arming.</i>
OUTP ON	<i>Enable the output to 5 V.</i>
TRIG	<i>Trigger the output voltage to 2.5 V.</i>
VOLT:TRIG 5;TRIG	<i>Set the pending trigger level to 5 V and trigger the output voltage back to 5 V.</i>
INIT:CONT OFF	<i>Remove the continuous trigger arming.</i>

Saving and Recalling States

You can remotely save and recall operating states. See ***SAV** and ***RCL** in "Chapter 3 - Language Dictionary" for the parameters that are saved and recalled.

Note When you turn the power supply on, it automatically retrieves the state stored in location 0. When a power supply is delivered, this location contains the factory defaults (see ***RST** in "Chapter 3 - Language Dictionary").

OUTP OFF;VOLT:LEV 6.5;PROT 6.8 *Program a desired operating state.*

CURR:LEV 335;PROT:STAT ON

***SAV 2**

Save this state to location 2.

***RCL 2**

(Later) recall this same state.

Writing to the Display

You can include messages to the front panel LCD in your programs. The description of **DISP:TEXT** in "Chapter 3 - Language Dictionary" shows the number and types of permitted display characters. In order to write to the display, you must first change it to text mode as shown in the following example:

DIS:MODE TEXT *Switch display to text mode.*

RECALLED 2 *Write "Recalled 2" to the display.*

DIS:MODE NORM *Return display to its normal mode.*

Programming Status

You can use status programming to make your program react to events within the power supply. "Chapter 4 - Status Reporting" explains the functions and bit configurations of all status registers. Refer to Figure 4-1 in that chapter while examining the examples given here.

Detecting Events via SRQ

Usually you will want the power supply to generate interrupts (assert SRQ) upon particular events. For this you must selectively enable the appropriate status register bits. The following examples allow the power supply to assert SRQ under selected conditions.

1. **STAT:OPER:ENAB 1280;PTR 1280;*SRE 128** *Assert SRQ when the supply switches between CV and CC modes.*
2. **STAT:OPER:ENAB 1;PTR 1;NTR 1;*SRE 128** *Assert SRQ when the supply enters or leaves calibration mode.*
3. **STAT:QUES 3;PTR 3;*SRE 128** *Assert SRQ when the supply goes into overvoltage or overcurrent condition.*
4. **STAT:OPER:ENAB 1280;PTR 1280;**
STAT:QUES 3;PTR 3;*SRE 136 *Assert SRQ under any event occurring in 1. or 3., above.*

Reading Specific Registers

You can exercise program control without interrupts by reading specific registers.

STAT:OPER:1280;EVEN? *Enable only the CV and CC events and read their status.*

STAT:OPER:ENAB 1313;PTR 1313;EVEN? *Enable all conditions of the Operation Status register and read any events.*

STAT:OPER:ENAB?;EVENT?;:STAT:QUES:ENAB?;EVEN?;:*ESE?;*ESR?

Read which events are active and which events are enabled in the Operation, Questionable, and Standard Event status registers.

Note The last query string can be handled without difficulty. However, should you request too many queries, the system may return a "Query DEADLOCKED" error (-430). In that case, break the long string into smaller parts.

Programming the Digital I/O Port

Digital control ports 1 and 2 are TTL outputs that can be programmed either high or low. Control port 3 can be programmed to be either a TTL input or a TTL output. Send a decimal parameter that translates into the desired straight binary code for these ports. (See **DIG:DATA[VAL]** in "Chapter 3 - Language Dictionary" for the port bit configurations.)

DIG:DATA 3 *Set ports 1 and 2 high and make 3 another output port.*

DIG:DATA 7 *Set ports 1 and 2 high and make 3 an input port.*

DIG:DATA? *Read back the present port configuration.*

System Considerations

The remainder of this chapter addresses some system issues concerning programming. These are power supply addressing and the use of the following types of GPIB system interfaces:

1. HP Vectra PC controller with Agilent 82335A GPIB Interface Command Library.
2. IBM PC controller with National Instruments GPIB-PCII Interface/Handler.
3. Agilent controller with Agilent BASIC Language System.

The GPIB Address

The power supply address cannot be set remotely; it must be set from the front panel. Once the address is set, you can assign it inside programs.

Setting the GPIB Address

Figure 4-6 in the power supply Operating Guide shows the ways the power supply can be connected to the GPIB bus. You can set up the GPIB address in one of three ways:

1. As a stand-alone supply (the only supply at the address). It has a primary address in the range of 0 to 30. For example:
5 or 7
2. As the direct supply in a serial link. It is the only supply connected directly to the GPIB bus. The primary address is unique and can be from 0 to 30. It is entered as an integer followed by a decimal separator. The secondary address always is 0, which may be added after the primary address. If the secondary address is omitted, it is assumed to be 0. For example:
5.0 or 7.
3. As a linked supply in serial link. It gets its primary address from the direct supply. It has a unique secondary address that can be from 1 to 15. It is entered as an integer preceded by a decimal separator. For example:
.1 or .12

When you enter a secondary address, leading zeros between the decimal separator and the first digit are ignored. For example, .1, .01, and .001 are accepted as secondary address 1 and displayed as 0.01. Zeros following a digit are not ignored. Thus, .10 and .010 are both accepted as secondary address 10 and displayed as 0.10.

Changing the Power Supply GPIB Address

Use the **Address** key and numerical keypad for entering addresses. The power supply is shipped with a 5 stand-alone address as the default. The general procedure for setting an address is:

Action	Display Shows
Press Address	Current address
Press new address keys	New address replaces numbers on the display
Press Enter	Display returns to meter mode

If you try to enter a forbidden number, **ADDR ERROR** is displayed.

The following examples show how to set addresses:

To set stand-alone primary address **6**, press **Address** **6** **Enter**

To set direct supply primary address **6**, press **Address** **6** **.** **Enter**

To set linked secondary address **1**, press **Address** **.** **1** **Enter**

To set linked secondary address **12**, press **Address** **.** **1** **2** **Enter**

Note The power supply display will reset (recall the state in location 0) whenever you change between the following types of GPIB addresses:

- A stand-alone primary address and a direct primary address.
 - A direct primary address and a secondary address.
-

Assigning the GPIB Address In Programs

The following examples assume that the GPIB select code is 7, the the power supply is 6, and that the power supply address will be assigned to the variable *@PS*.

```

1000  !Stand-alone address. The power supply will respond if it is set to 6
1010  PS=706                                !Statement for Agilent 82335A Interface
1010  ASSIGN @PS TO 706                      ! Statement for Agilent BASIC Interface
1020  !Direct address. The power supply will respond if it is set to 6. or 6.0
1030  PS=70600                              ! Statement for Agilent 82335A Interface
1030  ASSIGN @PS TO 70600                   ! Statement for Agilent BASIC Interface
1040  !Linked address 1. The power supply will respond if it is set to address .1 and is serially connected to a
      supply at direct address 6.0
1050  PS=706.01                             !Agilent 82335A Interface
1090  ASSIGN @PS TO 706.01                  !Agilent BASIC Interface

```

For systems using the National Instruments DOS driver, the address is specified in the software configuration program (IBCONFIG.EXE) and assigned a symbolic name. The address then is referenced only by this name within the application program (see the National Instruments GP-IB documentation).

DOS Drivers

Types of Drivers

The Agilent 82335A and National Instruments GP-IB are two popular DOS drivers. Each is briefly described here. See the software documentation supplied with the driver for more details.

Agilent 82335A Driver. For GW-BASIC programming, the GPIB library is implemented as a series of subroutine calls. To access these subroutines, your application program must include the header file SETUP.BAS, which is part of the DOS driver software.

SETUP.BAS starts at program line 5 and can run up to line 999. Your application programs must begin at line 1000. SETUP.BAS has built-in error checking routines that provide a method to check for GPIB errors during program execution. You can use the error-trapping code in these routines or write your own code using the same variables as used by SETUP.BAS.

National Instruments GP-IB Driver. Your program must include the National Instruments header file DECL.BAS. This contains the initialization code for the interface. Prior to running any applications programs, you must set up the interface with the configuration program (IBCONF.EXE).

Your application program will not include the power supply symbolic name and GPIB address. These must be specified during configuration (when you run IBCONF.EXE). Note that the primary address range is from 0 to 30 but any secondary address must be specified in the address range of 96 to 126. The power supply expects a message termination on EOI or line feed, so set *EOI w/last byte of Write*. It is also recommended that you set *Disable Auto Serial Polling*.

All function calls return the status word *IBSTA%*, which contains a bit (ERR) that is set if the call results in an error. When ERR is set, an appropriate code is placed in variable *IBERR%*. Be sure to check *IBSTA%* after every function call. If it is not equal to zero, branch to an error handler that reads *IBERR%* to extract the specific error.

Error Handling

If there is no error-handling code in your program, undetected errors can cause unpredictable results. This includes "hanging up" the controller and forcing you to reset the system. Both of the above DOS drivers have routines for detecting program execution errors.

Important Use error detection after every call to a subroutine.

Agilent BASIC Controllers

The Agilent BASIC Programming Language provides access to GPIB functions at the operating system level. This makes it unnecessary to have the header files required in front of DOS applications programs. Also, you do not have to be concerned about controller "hangups" as long as your program includes a timeout statement. Because the power supply can be programmed to generate SRQ on errors, your program can use an SRQ service routine for decoding detected errors. The detectable errors are listed in Table 5-1 of "Chapter 5 - Error Messages".

Sample Program Code

The following programs are intended only to show how some of the same power supply functions can be programmed to each of the three previously mentioned GPIB interfaces. The first two are for the DOS interfaces and the third for the Agilent BASIC interface.

Programming Some Power Supply Functions

SAMPLE FOR POWER SUPPLY AT STAND-ALONE ADDRESS 6. SEQUENCE SETS UP CV MODE OPERATION, FORCES SUPPLY TO SWITCH TO CC MODE, AND DETECTS AND REPORTS MODE CHANGE.

HP Vectra PC Controller Using Agilent 82335A Interface

```

5      ' < ----- Merge SETUP.BAS here ----- >
1000   MAX.ELEMENTS=2 : ACTUAL.ELEMENTS=0 :MAX.LENGTH=80 :ACT.LENGTH=0
1005   DIM OUTPUTS(2) :CDD$=SPACE$(40)
1010   ISC=7 :PS=706
1015   '
1020   'Set up the Power Supply Interface for DOS driver
1025   CALL IORESET (ISC)                                'Reset the interface
1030   IF PCIB.ERR < > NOERR THEN ERROR PCIB.BASERR
1035   TIMEOUT=3
1040   CALL IOTIMEOUT (ISC, TIMEOUT)                      'Set timeout to 3 seconds
1045   IF PCIB.ERR < > NOERR THEN ERROR PCIB.BASERR
1050   CALL IOCLEAR (ISC)                                  'Clear the interface
1055   IF PCIB.ERR <> NOERR THEN ERROR PCIB.BASERR
1060   CALL IOREMOTE (ISC)                                 'Set Power Supply to remote mode
1065   IF PCIB.ERR <> NOERR THEN ERROR PCIB.BASERR
1070   '
1075   'Program power supply to CV mode with following voltage and current
1080   CODES$ = "VOLTAGE 7.8;CURRENT 480"                   :GOSUB 2000
1085   '
1090   'Query power supply outputs & print to screen
1095   CODES$ = "MEASURE:VOLTAGE?;CURRENT?"                :GOSUB 2000 :GOSUB 3000
1100   VOUT = OUTPUTS(1)
1105   IOUT = OUTPUTS(2)
1110   PRINT "The output levels are "VOUT" Volts and "IOUT" Amps"
1115   '
1120   'Program triggered current level to value insufficient to maintain
1125   'supply within its CV operating characteristic
1130   CODES$ = "CURR:TRIG 50"                             :GOSUB 2000
1135   '
1140   'Set operation status mask to detect mode change from CV to CC
1145   CODES$ = "STAT:OPER:ENAB 1024;PTR 1024"            :GOSUB 2000
1150   '
1155   'Enable Status Byte OPER summary bit
1160   CODES$ = "**SRE 128"                                 :GOSUB 2000
1165   '
1170   'Arm trigger circuit and send trigger to power supply
1175   CODES$ = "INITIATE;TRIGGER"                         :GOSUB 2000
1180   '
1185   'Wait for supply to respond to trigger
1190   FOR I= 1 to 100 :NEXT I
1195   '
1200   'Poll for interrupt caused by change to CC mode and print to screen
1205   CALL IOS POLL (PS,RESPONSE)
1210   IF (RESPONSE AND 128)< >128 THEN GOTO 1240          'No OPER event to report
1215   CODES$ = "STATUS:OPER:EVEN?"                       :GOSUB 2000 'Query status oper register

```

Programming Some Power Supply Functions (continued)

```

1220 CALL IOENTER (PS,OEVENT)                                'Read back event bit
1225 IF PCIB.ERR < > NOERR THEN ERROR PCIB.BASERR
1230 IF (OEVENT AND 1024) = 1024 THEN PRINT "Supply switched to CC mode."
1240 'Clear the status circuit
1245 CODES$ = "*CLS" :GOSUB 2000
1260 FOR I = 1 TO 100 :NEXT I      'Wait for supply to clear
1265 '
1260 'Disable output and save present state in location 2
1265 CODES$ = "OUTPUT OFF;*SAV 2" :GOSUB 2000
1270 END
1275 '
2000 'Send command to power supply
2005 LENGTH = LEN(CODES$)
2010 CALL IOOUTPUTS (PS,CODES$,LENGTH)                       'Send command to interface
2015 IF PCIB.ERR < > NOERR THEN ERROR PCIB.BASERR           ISETUP.BAS error trap
2020 RETURN
2025 '
3000 'Get data from power supply
3005 CALL IOENTERA (PS,OUTPUTS(1),MAX.ELEMENTS,ACTUAL.ELEMENTS)
3010 IF PCIB.ERR < > NOERR THEN ERROR PCIB.BASERR
3015 RETURN
*****
                        IBM Controller Using National Interface
*****
990 ' ----- Merge DECL.BAS here -----
1000 'Power Supply Variable = PS% ; Stand-Alone Address = 706
1005 CODES$=SPACE$(50):MODE$=SPACE$(5):OEVENT$=SPACE$(20)
1010 D$=SPACE$(60):OUTPUT$=SPACE$(40):BDNAME$="PS%"
1015 DIM OUTPUT(2)
1020 '
1025 'Set up power supply interface for DOS driver
1030 CALL IBFIND(BDNAME$,PS%)
1035 IF PS%<0 THEN PRINT "IBFIND Failed."
1040 CALL IBCLR(PS%)
1045 '
1050 'Program power supply to CV mode with following voltage and current
1055 CODES$ = "VOLTAGE 7.8;CURRENT 480" :GOSUB 2000
1060 '
1065 'Query power supply outputs and print to screen
1070 CODES$ = "MEASURE:VOLTAGE?;CURRENT?" :GOSUB 2000 :GOSUB 3000
1075 VOUT = OUTPUT(1)
1080 IOUT = OUTPUT(2)
1085 PRINT "The programmed levels are "VOUT" Volts and "IOUT" Amps"
1090 '
1095 'Program triggered current level to value insufficient to maintain
1100 'supply within its CV operating characteristic
1105 CODES$ = "CURR:TRIG 50" :GOSUB 2000
1110 '
1115 'Set operation status mask to detect mode change from CV to CC
1120 CODES$ = "STAT:OPER:ENAB 1024;PTR 1024" :GOSUB 2000
1125 '

```

Programming Some Power Supply Functions (continued)

```

1130 'Enable Status Byte OPER summary bit
1135 CODES$ = ""SRE 128" :GOSUB 2000
1140 '
1146 'Arm trigger circuit and send trigger to power supply
1150 CODES$ = "INITIATE;TRIGGER" :GOSUB 2000
1160 'Wait for supply to respond to trigger
1165 FOR I= 1 to 100 :NEXT I
1170 '
1175 'Poll for interrupt caused by change to CC mode and print to screen
1180 SPOL%=0
1186 CALL IBRSP(PS%,SPOL%)
1190 IF (SPOL% AND 128) = 128 THEN POLL = 1 'Set interrupt flag on OPER bit
1195 IF POLL < > 1 THEN GOTO 1230 'No interrupt to service
1200 "CODES$ = "STAT:OPER:EVEN?" :GOSUB 2000 'Query status oper register
1205 CALL IBRD(PS%,OEVENT$) 'Read back event bit
1210 IF IBSTA% <0 THEN GOTO 2100
1215 OEVENT=VAL(OEVENT$)
1220 IF (OEVENT AND 1024) = 1024 THEN PRINT "Supply switched to CC mode."
1225 '
1230 'Clear status circuit
1235 CODES$=""CLS" :GOSUB 2000
1240 FOR I=1 TO 50 :NEXT I 'Wait for supply to clear
1245 '
1250 'Disable output and save present state to location 2
1255 CODES$ = "OUTPUT OFF;*SAV 2" :GOSUB 2000
1260 END
1265 '
2000 'Send command to power supply
2005 CALL IBWRT(PS%,CODES$)
2010 IF IBSTAT% < 0 THEN GOTO 2100 'Error detected
2015 RETURN
1250 'Disable output and save present state to location 2
1255 CODES$ = "OUTPUT OFF;*SAV 2" :GOSUB 2000
1260 END
1265 '
2000 'Send command to power supply
2005 CALL IBWRT(PS%,CODES$)
2010 IF IBSTAT% < 0 THEN GOTO 2100 'Error detected
2015 RETURN
2020 '
2100 'Error detection routine
2105 PRINT "GPIB error. IBSTAT%. = &H";HEX$(IBSTAT%)
2110 PRINT " IBERR% = ";IBERR% in line ";ERL
2115 STOP
2120 '
3000 'Get data from power supply
3005 CALL IBRD(PS%,OUTPUT$)
3010 IF IBSTA% < 0 THEN GOTO 2100
3015 I=1 'Parse data string
3020 X=1
3025 C=INSTR(I,OUTPUT$,";")

```

Programming Some Power Supply Functions (continued)

```

3030 WHILE C < > 0
3035   D$=MID$(OUTPUT$,I,C-I)
3040   OUTPUT(X)=VAL(D$)           'Get values
3045   I=C+1
3050   C=INSTR(I,OUTPUT$,";")
3055   X=X+1
3060 WEND
3065 D$=RIGHT$(OUTPUT$,LEN(OUTPUT$)-(I-1))
3070 OUTPUT(X)=VAL(D$)
3076 OUTPUT$=SPACE$(40)         'Clear string
3080 RETURN
*****
      Controller Using Agilent BASIC
*****
1000 !Power supply at stand-alone address = 706
1005 OPTION BASE 1
1010 DIM Codes$(80),Response$(80),Mode$(32)
1015 !
1020 !Program power supply to CV mode with following voltage and current
1026 OUTPUT 706;"VOLTAGE 7.8;CURRENT 480"
1030 !
1035 !Query power supply outputs and print to screen
1040 OUTPUT 706;"MEASURE:VOLTAGE?;CURRENT?"           !Query output levels
1045 ENTER 706;Vout, Iout
1050 PRINT "The output levels are ";Vout;" Volts and ";Iout;" Amps"
1055 !
1060 !Program current triggered level to a value insufficient to maintain
1065 !supply within its CV operating characteristic
1070 OUTPUT 706;"CURR:TRIG 50"
1075 !
1080 !Set operation status mask to detect mode change from CV to CC
1085 OUTPUT 706;"STAT:OPER:ENAB 1280;PTR 1280"
1090 !
1095 !Enable Status Byte OPER summary bit
1100 OUTPUT 706;"*SRE 128"
1105 !
1110 !Arm trigger circuit and send trigger to power supply
1115 OUTPUT 706;"INITIATE;TRIGGER"
1130 !Poll for interrupt caused by change to CC mode and print to screen
1135 Response=SPOLL(706)
1140 IF NOT BIT (Response,7) THEN GOTO 1130           !No OPER event to report
1145 OUTPUT 706;"STAT:OPER:EVEN?"                   !Query status operation register
1160 ENTER 706;Oevent                                !Read back event bit
1156 IF BIT(Oevent,10) THEN PRINT "Supply switched to CC mode."
1160 !
1165 !Clear status
1170 OUTPUT 706;"*CLS"
1176 !
1180 !Disable output and save present state in location 2
1185 OUTPUT 706;"OUTPUT OFF;*SAV 2"
1190 END

```

Language Dictionary

Introduction

This section gives the syntax and parameters for all the IEEE 488.2 SCPI commands and the Common commands used by the power supply. It is assumed that you are familiar with the material in "Chapter 2 - Remote Programming". That chapter explains the terms, symbols, and syntactical structures used here and gives an introduction to programming. You should also be familiar with "Chapter 5 - Front Panel Operation" (in the Operating Guide) in order to understand how the power supply functions.

The programming examples are simple applications of SCPI commands. Since SCPI syntax remains the same for all programming languages, the examples are generic.

Syntax definitions use the long form, but only short form headers (or "keywords") appear in the examples. If you have any concern that the meaning of a header in your program listing will not be obvious at some later time, then use the long form to help make your program self-documenting.

Parameters

Most commands require a parameter and all queries will return a parameter. The range for a parameter may vary according to the model of power supply. Parameters for all current models are listed in Table 3-1 at the end of this chapter.

Related Commands

Where appropriate, related commands or queries are included. These are listed either because they are directly related by function or because reading about them will clarify or enhance your understanding of the original command or query.

Order of Presentation

The dictionary is organized as follows:

- IEEE 488.2 common commands, in alphabetical order.
- Subsystem commands.

Common Commands

Common commands begin with an * and consist of three letters (command) or three letters and a ? (query). *Common* commands are defined by the IEEE 488.2 standard to perform some common interface functions. The power supply responds to the 13 required common commands that control status reporting, synchronization, and internal operations. The power supply also responds to five optional common commands controlling triggers, power-on conditions, and stored operating parameters.

Subsystem Commands

Subsystem commands are specific to power supply functions. They can be a single command or a group of commands. The groups are comprised of commands that extend one or more levels below the root. The description of subsystem commands follows the listing of the common commands.

Description Of Common Commands

Figure 3-1 shows the common commands and queries. These commands are listed alphabetically in the dictionary. If a command has a corresponding query that simply returns the data or status specified by the command, then both command and query are included under the explanation for the command. If a query does not have a corresponding command or is functionally different from the command, then the query is listed separately. The description of each common command or query specifies any status registers affected. In order to make use of this information, you must refer to "Chapter 4 - Status Reporting", which explains how to read specific register bits and use the information that they return.

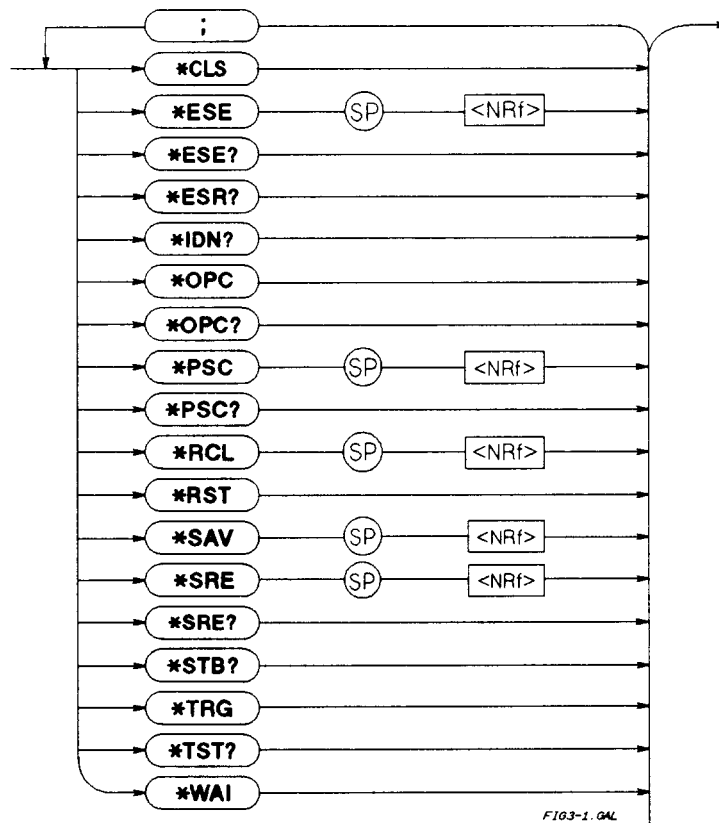

Figure 3-1. Common Commands Syntax Diagram

*CLS

Meaning and Type

Clear Status Device Status

Description

This command causes the following actions (see "Chapter 4 - Status Reporting" for descriptions of all registers):

- Clears the following registers:
 - Standard Event Status.
 - Operation Status Event.
 - Questionable Status Event.
 - Status Byte.
- Clears the Error Queue.

- If ***CLS** immediately follows a program message terminator (<NL>), then the output queue and the MAV bit are also cleared.

Command Syntax ***CLS**
Parameters (None)
Query Syntax (None)

***ESE**

Meaning and Type

Event Status Enable Device Status

Description

This command programs the Standard Event Status Enable register bits. The programming determines which events of the Standard Event Status Event register (see ***ESR?**) are allowed to set the ESB (Event Summary Bit) of the Status Byte register. A "1" in the bit position enables the corresponding event. All of the enabled events of the Standard Event Status Event register are logically ORed to cause the Event Summary Bit (ESB) of the Status Byte register to be set. See "Chapter 4 - Status Reporting" for descriptions of all three registers.

Bit Configuration of Standard Event Status Enable Register

Bit Position	7	6	5	4	3	2	1	0
Bit Name	PON	0	CME	EXE	DDE	QYE	0	OPC
Bit Weight	128	64	32	16	8	4	2	1

CME = Command error; DDE = Device-dependent error; EXE = Execution error;
 OPC = Operation complete; PON Power-on; QYE = Query error.

Command Syntax ***ESE <Nrf>**
Parameters *0 to 255*
Power On Value (See ***PSC**)
Suffix (None)
Example ***ESE 129**
Query Syntax ***ESE?**
Returned Parameters **<NR1>** (Register value)
Related Commands ***ESR? *PSC *STB?**



If **PSC** is programmed to 0, then the ***ESE** command causes a write cycle to nonvolatile memory. The nonvolatile memory has a finite maximum number of write cycles (see Supplemental Characteristics in Chapter 1 of the power supply Operating Guide). Programs that repeatedly cause write cycles to nonvolatile memory can eventually exceed the maximum number of write cycles and may cause the memory to fail.

***ESR?**

Meaning and Type

Event Status Register Device Status

Description

This query reads the Standard Event Status Event register. Reading the register clears it. The bit configuration of this register is the same as the Standard Event Status Enable register (***ESE**). See "Chapter 4 - Status Reporting" for a detailed explanation of this register.

Query Syntax ***ESR?**
Parameters (None)
Returned Parameters **<NR1>** (Register binary value)
Related Commands ***CLS *ESE *ESE? *OPC**

*IDN?

Identification Query

Meaning and Type

Identification System Interface

Description

This query requests the power supply to identify itself. It returns a string composed of four fields separated by commas.

Query Syntax	*IDN?	
Returned Parameters	<AARD>	
	Field	Information
	<i>Agilent Technologies</i>	Manufacturer
	xxxxA	4-digit model number followed by a letter suffix
	nnnnA-nnnnn	10-character serial number or 0
	<R>.xx.xx	Revision levels of firmware
Example	Agilent Technologies,6681,0,A.00.01	
Related Commands	(None)	

*OPC

Meaning and Type

Operation Complete Device Status

Description

This command causes the interface to set the OPC bit (bit 0) of the Standard Event Status register when the power supply has completed all pending operations. (See *ESE for the bit configuration of the Standard Event Status register.) *Pending operations* are complete when:

- All commands sent before *OPC have been executed. This includes overlapped commands. Most commands are sequential and are completed before the next command is executed. Overlapped commands are executed in parallel with other commands. Commands that affect output voltage, current or state, relays, and trigger actions are overlapped with subsequent commands sent to the power supply. The *OPC command provides notification that all overlapped commands have been completed.
- Any change in the output level caused by previous commands has been completed (completion of settling time, relay bounce, etc.)
- All triggered actions are completed

*OPC does not prevent processing of subsequent commands but Bit 0 will not be set until all pending operations are completed.

Command Syntax	*OPC
Parameters	(None)
Related Commands	*OPC? *WAI

*OPC?

Meaning and Type

Operation Complete Device Status

Description

This query causes the interface to place an ASCII "1" in the Output Queue when all pending operations are completed. *Pending operations* are as defined for the *OPC command. Unlike *OPC, *OPC? prevents processing of all subsequent commands. *OPC? is intended to be used at the end of a command line so that the application program can then monitor the bus for data until it receives the "1" from the power module Output Queue.

CAUTION	Do not follow *OPC? with *TRG or GPIB bus triggers. Such triggers sent after *OPC? will be prevented from executing and will prevent the power supply from accepting further commands. If this occurs, the only programmable way to restore operation is by sending the power supply a GPIB DCL (Device Clear) command.
----------------	---

Query Syntax	*OPC?	
Returned Parameters	<NR1>	ASCII 1 is placed in the Output Queue when the power supply has completed operations.
Related Commands	*OPC *TRIG *WAI	

*OPT?

Meaning and Type

Option Identification Query

Description

This query requests the power supply to identify any options that are installed. Options are identified by number A. 0 indicates no options are installed.

Query Syntax	*OPT?
Returned Parameters	<AARD>

*PSC

Meaning and Type

Power-on Status Clear Device Initialization

Description

This command controls the automatic clearing at power turn-on of:

- The Service Request Enable register.
- The Standard Event Status Enable register.

If the command parameter = 1, then the above registers are cleared at power turn-on. If the command parameter = 0, then the above registers are not cleared at power turn-on but are programmed to their last state prior to power turn on. This is the most common application for *PSC and enables the power module to generate an SRQ (Service Request) at power on.

Command Syntax	*PSC <bool>
Parameters	0 1 OFF ON
Example	*PSC 0 *PSC 1
Query Syntax	*PSC?
Returned Parameters	<NR1> 0 1
Related Commands	*ESE *SRE

CAUTION

*PSC causes a write cycle to nonvolatile memory. If *PSC is programmed to 0, then the *ESE and *SRE commands also cause a write cycle to nonvolatile memory. The nonvolatile memory has a finite number of write cycles (see "Table 1-2, Supplementary Characteristics"). Programs that repeatedly write to nonvolatile memory can eventually exceed the maximum number of write cycles and may cause the memory to fail.

*RCL

Meaning and Type

Recall Device State

WARNING

Recalling a previously stored state may place hazardous voltage at the power supply output.

Description

This command restores the power supply to a state that was previously stored in memory with a *SAV command to the specified location. The following states are recalled:

CURR[:LEV][:IMM]	OUTP[:STAT]	OUTP:REL:POL
CURR:PROT:STAT	OUTP:PROT:DEL	VOLT[:LEV][:IMM]
DIG:DATA[:VAL]	OUTP:REL[:STAT]	VOLT:PROT[:LEV]

Sending *RCL also does the following:

- Forces an **ABORT** command before resetting any parameters (this cancels any uncompleted trigger actions).
- Disables the calibration function by setting **CAL:STATe** to **OFF**.
- Sets display functions as follows:
 - **DISP[:WIND][:STATe]** to **ON**.
 - **DISP[:WIND]:MODE** to **NORMAL**.
 - **DISP[:WIND]:TEXT** to ' '.
- Sets **INIT:CONT** to **OFF**.
- Sets **TRIG:SOUR** to **BUS**.

At power turn-on, the power supply normally is returned to the factory defined turn-on state (see *RST). However, it also may turn on to the state stored in location 0 (see *Turn-On Condition* under "Chapter 5 - Front Panel Operation" of the power supply Operating Guide).

Command Syntax	*RCL <NRf>
Parameters	0 1 2 3
Example	*RCL 3
Query Syntax	(None)
Related Commands	*PSC *RST *SAV

*RST

Meaning and Type

Reset Device State

Description

This command resets the power supply to a factory-defined state as defined below. *RST also forces an **ABORT** command.

<u>Command</u>	<u>State</u>
CAL:STAT <i>OFF</i>	OUTP[:STAT] <i>OFF</i>
CURR[:LEV][:IMM] *	OUTP:PROT:DEL *
CURR[:LEV]:TRIG *	OUTP:REL[:STAT] <i>OFF</i>
CURR:PROT:STAT <i>OFF</i>	OUTP:REL:POL <i>NORM</i>
DIG:DATA <i>0</i>	TRIG:SOUR <i>BUS</i>
DISP[:WIND]:STAT <i>ON</i>	VOLT[:LEV][:IMM] *
DISP[:WIND]:MODE <i>NORM</i>	VOLT[:LEV]:TRIG *
DISP[:WIND]:TEXT	VOLT:PROT[:LEV] *
INIT:CONT <i>OFF</i>	

* Model-dependent value. See Table 3-1.

Command Syntax	*RST
Parameters	(None)
Query Syntax	(None)
Related Commands	*PSC *SAV

*SAV

Meaning and Type

SAVE Device State

Description

This command stores the present state of the power supply to the specified location in memory. Up to four states can be stored. Under certain conditions (see "Turn-On Conditions" in "Chapter 5 - Front Panel Operation" of the Operating Guide), location *0* may hold the device state that is automatically recalled at power turn-on.

The following power supply parameters are stored by *SAV:

CURR[:LEV][:IMM]	OUTP[:STAT]	OUTP:REL:POL
CURR:PROT:STAT	OUTP:PROT:DEL	VOLT[:LEV][:IMM]
DIG:DATA[:VAL]	OUTP:REL[:STAT]	VOLT:PROT[:LEV]

Command Syntax	*SAV <NRf>
Parameters	0 1 2 3
Example	SAV 3
Query Syntax	(None)
Related Commands	*RCL *RST

CAUTION

The power supply uses nonvolatile memory for recording register states. Programs that repeatedly use *SAV for recalling states cause frequent write cycles to the memory and can eventually exceed the maximum number of write cycles for the memory (see in the power supply Operating Guide).

*SRE

Meaning and Type

Service Request Enable Device Interface

Description

This command sets the condition of the Service Request Enable Register. This register determines which bits from the Status Byte Register (see *STB for its bit configuration) are allowed to set the Master Status Summary (MSS) bit and the Request for Service (RQS) summary bit. A 1 in any Service Request Enable Register bit position enables the corresponding Status Byte Register bit and all such enabled bits then are logically ORed to cause Bit 6 of the Status Byte Register to be set. See "Chapter 4 - Status Reporting" for more details concerning this process.

When the controller conducts a serial poll in response to SRQ, the RQS bit is cleared, but the MSS bit is not. When *SRE is cleared (by programming it with 0), the power supply cannot generate an SRQ to the controller.

Command Syntax	*SRE <NRf>
Parameters	0-to 255
Default Value	(See *PSC)
Example	*SRE 20
Query Syntax	*SRE?
Returned Parameters	<NR1> (Register binary value)
Related Commands	*ESE *ESR *PSC



If *PSC is programmed to 0, then the *SRE command causes a write cycle to nonvolatile memory. The nonvolatile memory has a finite number of write cycles (see Supplemental Characteristics in the power supply Operating Guide). Programs that repeatedly write to nonvolatile memory can eventually exceed the maximum number of write cycles and may cause the memory to fail.

*STB?

Meaning and Type

Status Byte Device Status

Description

This query reads the Status Byte register, which contains the status summary bits and the Output Queue MAV bit. Reading the Status Byte register does not clear it. The input summary bits are cleared when the appropriate event registers are read (see "Chapter 4 - Status Reporting" for more information). The MAV bit is cleared at power on or by *CLS.

A serial poll also returns the value of the Status Byte register, except that bit 6 returns. Request for Service (RQS) instead of Master Status Summary (MSS). A serial poll clears RQS, but not MSS. When MSS is set, it indicates that the power supply has one or more reasons for requesting service.

Bit Configuration of Status Byte Register

Bit Position	7	6	5	4	3	2	1	0
Condition	OPER	MSS ¹ (RQS)	ESB	MAV	QUES	²	²	²
Bit Weight	128	64	32	16	8	4	2	1
ESB = Event status byte summary; MAV = Message available.								
MSS = Master status summary; OPER = Operation status summary.								
QUES = Questionable status summary; RQS = Request for service.								
¹ Also represents RQS. ² These bits are always zero.								

Query Syntax	*STB?	
Returned Parameters	<NR1>	(Register binary value)
Related Commands	(None)	

***TRG**

Meaning and Type

Trigger Device Trigger

Description

This command generates a trigger when the trigger subsystem has **BUS** selected as its source. The command has the same affect as the Group Execute Trigger (<GET>) command.

Command Syntax	*TRG
Parameters	(None)
Query Syntax	(None)
Related Commands	ABOR CURR:TRIG INIT TRIG[:IMM] VOLT:TRIG <GET>

***TST?**

Meaning and Type

Test Device Test

Description

This query causes the power supply to do a self-test and report any errors (see "Selftest Error Messages" in "Chapter 3 - Turn-On Checkout" of the power supply Operating Guide).

Query Syntax	*TST?	
Returned Parameters	<NR1>	
	0	Indicates power supply passed self-test.
	Nonzero	Indicates an error code.
Related Commands	(None)	

***WAI**

Meaning and Type

Wait to Continue Device Status

Description

This command instructs the power supply not to process any further commands until all pending operations are completed. "Pending operations" are as defined under the ***OPC** command. ***WAI** can be aborted only by sending the power supply a GPIB **DCL** (Device Clear) command.

Command Syntax	*WAI
Parameters	(None)
Query Syntax	(None)
Related Commands	*OPC *OPC?

Description Of Subsystem Commands

Figure 3-2 is a tree diagram of the subsystem commands. Commands followed by a question mark (?) take only the query form. Except as noted in the syntax descriptions, all other commands take both the command and query form. The commands are listed in alphabetical order and the commands within each subsystem are grouped alphabetically under the subsystem.

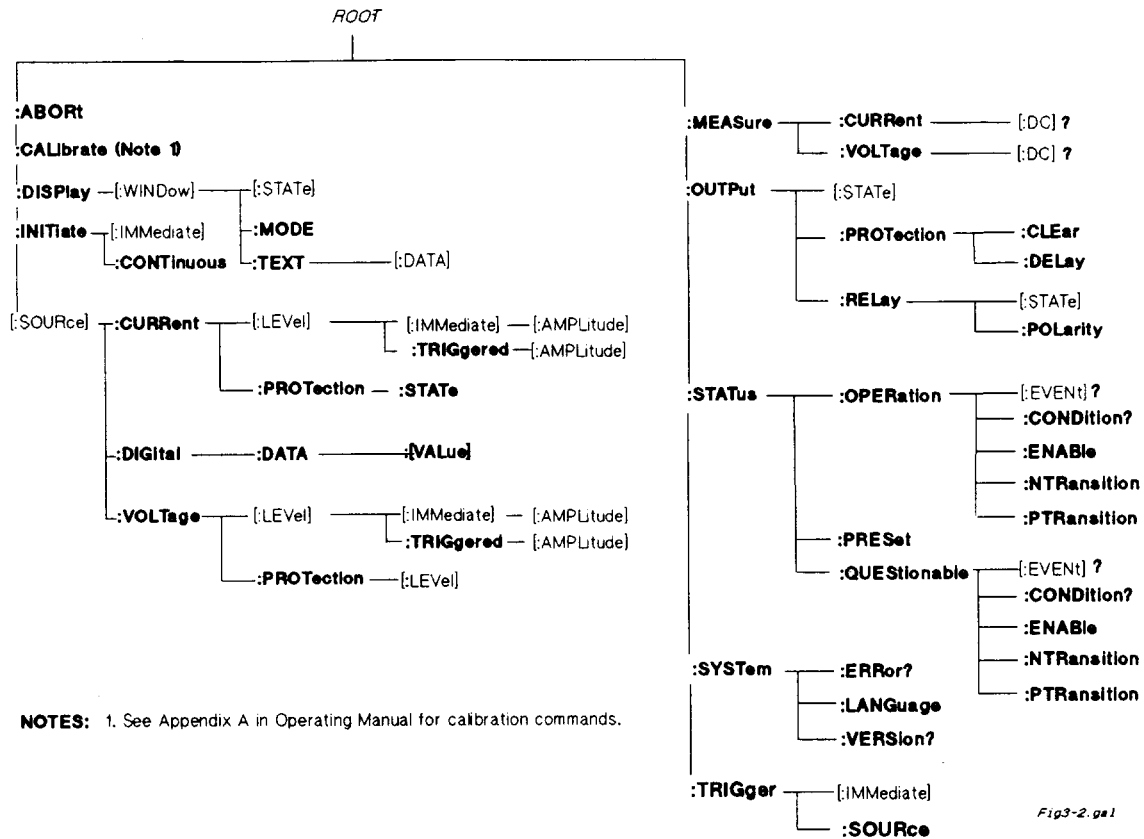

Figure 3-2. Subsystem Commands Tree Diagram

ABOR

This command cancels any trigger actions presently in process. Pending trigger levels are reset equal to their corresponding immediate values. **ABOR** also resets the WTG bit in the Operation Condition Status register (see "Chapter 4 - Status Reporting"). If **INIT:CONT ON** has been programmed, the trigger subsystem initiates itself immediately after **ABOR**, thereby setting WTG. **ABOR** is executed at power turn on and upon execution of ***RCL** or **RST**.

Command Syntax	ABORt
Parameters	(None)
Examples	ABOR
Query Syntax	(None)
Related Commands	INIT *RST *TRG TRIG

Calibration Commands

See Appendix A in the power supply Operating Guide.

Current Subsystem

This subsystem programs the output current of the power supply.

CURR

CURR:TRIG

These commands set the immediate current level or the pending triggered current level of the power supply. The immediate level is the current programmed for the output terminals. The pending triggered level is a stored current value that is transferred to the output terminals when a trigger occurs. A pending triggered level is unaffected by subsequent **CURR** commands and remains in effect until the trigger subsystem receives a trigger or an **ABORT** command is given. If there is no pending **CURR:TRIG** level, then the query form returns the **CURR** level. In order for **CURR:TRIG** to be executed, the trigger subsystem must be initiated (see **INITiate**).

Command Syntax	[SOURce]: CURRent [: LEVel] [: IMMediate][: AMPLitude] <NRf+> [SOURce][: CURRent [: LEVel]: TRIGgered][: AMPLitude] <NRf+>
Parameters	Table 3-1
Default Suffix	A
*RST Value	Table 3-1
Examples	CURR 200 MA CURRENT:LEVEL 200 MA CURRENT:LEVEL:IMMEDIATE:AMPLITUDE 2.5 CURR:TRIG 20 CURRENT:LEVEL:TRIGGERED 20
Query Syntax	[SOURce]: CURRent [: LEVel] [: IMMediate][: AMPLitude]? [SOURce]: CURRent [: LEVel] [: IMMediate][: AMPLitude]? MAX [SOURce]: CURRent [: LEVel] [: IMMediate][: AMPLitude]? MIN [SOURce]: CURRent [LEVel]: TRIGgered [: AMPLitude]? [SOURce]: CURRent [LEVel]: TRIGgered [: AMPLitude]? MAX [SOURce]: CURRent [: LEVel]: TRIGgered [: AMPLitude]? MIN
Returned Parameters	<NR3> CURR? and CURR:TRIG? return presently programmed immediate and triggered levels. If not triggered level is programmed, both returned values are the same. CURR? MAX and CURR? MIN return the maximum and minimum programmable immediate current levels. CURR:TRIG? MAX and CURR:TRIG? MIN return the maximum and minimum programmable triggered current levels.
Related Commands	For CURR *SAV *RCL *RST For CURR:TRIG ABOR CURR *RST

CURR:PROT:STAT

This command enables or disables the power supply overcurrent protection (OCP) function. If the overcurrent protection function is enabled and the power supply goes into constant-current operation, then the output is disabled and the Questionable Condition status register OC bit is set (see "Chapter 4 - Status Reporting"). An overcurrent condition can be cleared with the **OUTP:PROT:CLE** command after the cause of the condition is removed.

Command Syntax	[SOURce]: CURRent : PROT ection: STAT e <bool>
Parameters	0 1 OFF ON
*RST Value	OFF
Examples	CURR:PROT:STAT 0 CURRENT:PROTECTION:STATE OFF CURR:PROT:STAT 1 CURRENT:PROTECTION:STATE ON
Query Syntax	[SOURce]: CURRent : PROT ection: STAT e?
Returned Parameters	<NRI> <i>0</i> or <i>1</i>
Related Commands	OUTP:PROT:CLE *RST

DIG:DATA

This command sets and reads the power supply digital control port when that port is configured for Digital I/O operation. Configuring of the port is done via an internal jumper (see Appendix D in the Operating Guide). The port has three signal pins and a digital ground pin. Pins 1 and 2 are output pins controlled by bits 0 and 1. Pin 3 is controlled by bit 3 and can be programmed to serve either as an input or an output. Pin 4 is the digital ground.

Bit position 2 normally serves as an output. To change it to an input, it must first be programmed high. The **DIG:DATA?** query returns the last programmed value in bits 0 and 1 and the value read at pin 3 in bit 2. The bits are turned on and off in straight binary code as follows:

Digital I/O Port Programming Chart

Value	Bit Configuration				Pin Configuration ¹				Value	Bit Configuration				Pin Configuration ¹			
	0	1	2		1	2	3	4		0	1	2		1	2	3	4
0	0	0	0		Lo	Lo	Output	Gnd	4	0	0	1		Lo	Lo	Input	Gnd
1	1	0	0		Hi	Lo	Output	Gnd	5	1	0	1		Hi	Lo	Input	Gnd
2	0	1	0		Lo	Hi	Output	Gnd	6	0	1	1		Lo	Hi	Input	Gnd
3	1	1	0		Hi	Hi	Output	Gnd	7	1	1	1		Hi	Hi	Input	Gnd

¹Pins 1 and 2 are always outputs

Command Syntax	[SOURCE]:DIGital:DATA[:VALue] <NRf>
Parameters	0 to 7
Suffix	(None)
*RST Value	0
Examples	DIG:DATA 7 DIGITAL:DATA:VALUE 7
Query Syntax	[SOURCE]:DIGital:DATA?
Returned Parameters	<NRI> Values from 0 to 7
Related Commands	*RST *RCL *SAV

Display Subsystem

This subsystem controls the state and output of the alphanumeric portion of the display.

DISP

Enables or disables the display. When disabled, the display characters are blank. The annunciators are not affected by this command.

Command Syntax	DISPlay[:WINDow][:STATe] <bool>
Parameters	0 1 OFF ON
Suffix	(None)
*RST Value	ON
Examples	DISP ON DISPLAY:STATE ON
Query Syntax	DISPlay[:WINDow][:STATe]?
Returned Parameters	<NR1> 0 or 1
Related Commands	DISP:MODE DISP:TEXT *RST

DISP:MODE

Switches the display between its normal metering mode and a mode in which it displays text sent by the user. The command uses the character data <CRD> format.

Command Syntax	DISPlay[:WINDow]:MODE NORMAl TEXT
Parameters	<CRD> NORMAl TEXT
*RST Value	NORM
Examples	DISP:MODE NORM DISPLAY:MODE NORMAL DISPLAY:WINDOW:MODE TEXT
Query Syntax	DISPlay[:WINDow]:MODE?
Returned Parameters	<CRD> <i>NORMAL</i> or <i>TEXT</i>
Related Commands	DISP DISP:TEXT *RST

DISP:TEXT

Allows character strings to be sent to display. The characters will be displayed when the display mode is TEXT. The LCD has the following character set:

LCD Character Set

uppercase letters	A through Z (Case-sensitive entry)
digits	0 through 9
punctuation	_ “ \$ <> + - / = ? . : ,
blank space	

A display is capable of showing up to 12 characters. However, the three punctuation characters do not count toward the 12-character limit when they are preceded by an alphanumeric character. When punctuation characters are included, then the maximum number of characters (alphanumeric + punctuation) that can be displayed is 15. If it exceeds the display capacity, a message will be truncated to fit and no error message will be generated. If any character in the message is not a member of the above character set, the character will not be rejected but will be displayed as a "starburst" (all 16 segments of the character will light).

Command Syntax	DISPlay[:WINDow]:TEXT [:DATA] <STR>
Parameters	(See LCD character set)
*RST Value	' '
Examples	DISP:TEXT "DEFAULT_MODE" DISPLAY:WINDOW:TEXT:DATA '533.2E-1VOLTS'
Query Syntax	DISPlay[:WINDow]:TEXT?
Returned Parameters	<STR> (Last programmed text string)
Related Commands	DISP DISP:MODE *RST

Note

IEEE Standard Digital Interface for Programmable Instrumentation requires that a string be enclosed in either single (') or double (") quotes.

Initiate Subsystem

This subsystem enables the trigger system. When a trigger is enabled, an event on a selected trigger source causes the specified triggering action to occur. If the trigger subsystem is not enabled, all trigger commands are ignored. If **INIT:CONT** is **OFF**, then **INIT** enables the trigger subsystem only for a single trigger action. The subsystem must be enabled prior to each subsequent trigger action. If **INIT:CONT** is **ON**, then the trigger subsystem is continuously enabled and **INIT** is redundant.

Command Syntax	INITiate[:IMMediate]
Parameters	INITiate:CONTinuous <bool> For INIT[:IMM] (None) For INIT:CONT 0 1 OFF ON
*RST Value	OFF
Examples	INIT INITIATE:IMMEDIATE INIT:CONT 1 INITIATE:CONTINUOUS 1
Query Syntax	For INIT[:IMM] (None) For INIT:CONT INIT:CONT?
Returned Parameters	<NR1> 0/1
Related Commands	ABOR <GET> *RST TRIG *TRG

Measure Subsystem

This query subsystem returns the voltage and current measured at the power supply's sense terminals.

Query Syntax	MEASure:CURRent[:DC]? MEASure:VOLTage[:DC]?
Parameters	(None)
Default Suffix	A for MEAS:CURR? V for MEAS:VOLT?
Examples	MEAS:CURR? MEAS:VOLT? MEASURE:VOLTAGE:DC? MV
Returned Parameters	<NR3>

Output Subsystem

This subsystem controls the power supply's voltage and current outputs and an optional output relay.



Do not install or program the Agilent Relay Accessories if the power supply maximum output current rating (see Table 3-1) exceeds the contact ratings of the relay.

OUTP

This command enables or disables the power supply output. The state of a disabled output is a condition of zero output voltage and a model-dependent minimum source current (see Table 3-1). The query form returns the output state.

Command Syntax	OUTPut[:STATe] <bool>
Parameters	0 OFF 1 ON
Suffix	(None)
*RST Value	0
Examples	OUTP 1 OUTPUT:STATE ON
Query Syntax	OUTPut(:STATe)?
Returned Parameters	<NR1> 0 or 1
Related Commands	*RST *RCL *SAV

OUTP:PROT

There are two output protection commands that do the following:

OUTP:PROT:CLE Clears any OV (overvoltage), OC (overcurrent, unless set via external voltage control), OT (overtemperature), or RI (remote inhibit) protection features. After this command, the output is restored to the state it was in before the protection feature occurred.

OUTP:PROT:DEL Sets the time between the programming of an output change that produces a CV, CC, or UNREG condition and the recording of that condition by the Status Operation Condition register. The delay prevents the momentary changes in power supply status that can occur during reprogramming from being registered as events by the status subsystem. Since the delay applies to CC status, it also delays the OCP (overcurrent protection) feature. The OVP (overvoltage protection) feature is not affected by this delay.

Examples	OUTP:PROT:CLE OUTPUT:PROTECTION:CLEAR OUTPUT:PROTECTION:DELAY 75E-1 OUTP:PROT:DEL MIN OUTPUT:PROT:DELAY MAX
Query Syntax	OUTP:PROT:CLE (None) OUTPut:PROTection:DELAy? OUTPut:PROTection:DELAy? MIN OUTPut:PROTection:DELAy? MAX
Returned Parameters	<NR3> OUTP:PROT:DEL? returns value of programmed delay. OUTP:PROT:DEL? MIN and OUTP:PROT:DEL? MAX return the minimum and maximum programmable delays.
Related Commands	OUTP:PROT:CLE (None) OUTP:PROT:DEL *RST *RCL *SAV

OUTP:REL

CAUTION	Do not install or program the Agilent Relay Accessories if the power supply maximum output current rating (see Table 3-1) exceeds the contact ratings of the relay.
----------------	---

This command is valid only if the power supply is configured for the optional relay connector. Programming **ON** closes the relay contacts; programming **OFF** opens them. The relay is controlled independently of the output state. If the power supply is supplying power to a load, that power will appear at the relay contacts during switching. If the power supply is not configured for the relay option, sending either relay command generates an error.

Command Syntax	OUTPut:RELAy[:STATe] <bool>
Parameters	0 1 OFF ON
*RST Value	0
Examples	OUTP:REL 1 OUTP:REL OFF
Query Syntax	OUTPput:RELAy?
Returned Parameters	0 1
Related Commands	OUTP[:STAT] *RCL *SAV

OUTP:REL:POL



Do not install or program the Agilent Relay Accessories if the power supply maximum output current rating (see Table 3-1) exceeds the contact ratings of the relay.

This command is valid only if the power supply is configured for the optional relay connector. Programming **NORMAL** causes the relay output polarity to be the same as the power supply output. Programming **REVERSE** causes the relay output polarity to be opposite to that of the power supply output. If **OUTP[:STAT] = ON** when either relay command is sent, the power supply output voltage is set to 0 during the time that the relays are changing polarity.

If the power supply is not configured for the relay option, sending either relay command generates an error.

Command Syntax	OUTPut:RELAy:POLarity <CRD>
Parameters	NORMAL REVERSE
*RST Value	NORM
Examples	OUTP:REL:POL NORM
Query Syntax	OUTPput:RELAy:POLarity?
Returned Parameters	NORM REV
Related Commands	OUTP[:STAT] *RCL *SAV

Status Subsystem

This subsystem programs the power supply status registers. The power supply has three groups of status registers; **Operation**, **Questionable**, and **Standard Event**. The Standard Event group is programmed with Common commands as described in "Chapter 4 - Status Reporting". The Operation and Questionable status groups each consist of the Condition, Enable, and Event registers and the NTR and PTR filters.

Status Operation Registers

The bit configuration of all Status Operation registers is shown in the following table:

Bit Configuration of Operation Registers

Bit Position	15-12	11	10	9	8	7	6	5	4	3	2	1	0
Bit Name	NU	NU	CC	NU	CV	NU	NU	WTG	NU	NU	NU	NU	CAL
Bit Weight		2048	1024	512	256	128	64	32	16	8	4	2	1

CAL = Interface is computing new calibration constants; CC = The power module is in constant current mode.
CV = The power module is in constant voltage mode; NU = (Not used); WTG = Interface is waiting for a trigger.

Note

See "Chapter 4 - Status Reporting" for more explanation of these registers.

STAT:OPER?

This query returns the value of the Operation Event register. The Event register is a read-only register which holds (latches) all events that are passed by the Operation NTR and/or PTR filter. Reading the Operation Event register clears it.

Query Syntax	STATus:OPERtion[:EVENT]?
Parameters	(None)
Returned Parameters	<NR1> (Register Value)
Examples	STAT:OPER? STATUS:OPERATIOBAL:EVENT?
Related Commands	*CLS STAT:OPER:NTR STAT:OPER:PTR

STAT:OPER:COND?

This query returns the value of the Operation Condition register. That is a read-only register which holds the real-time (unlatched) operational status of the power supply.

Query Syntax	STATus:OPERation:CONDition?
Parameters	(None)
Examples	STAT:OPER:COND? STATUS:OPERATION:CONDITION?
Returned Parameters	<NR1> (Register value)
Related Commands	(None)

STAT:OPER:ENAB

This command and its query set and read the value of the Operational Enable register. This register is a mask for enabling specific bits from the Operation Event register to set the operation summary bit (OPER) of the Status Byte register. This bit (bit 7) is the logical OR of all the Operational Event register bits that are enabled by the Status Operation Enable register.

Command Syntax	STATus:OPERation:ENABLE <NRf>
Parameters	0 to 32727
Suffix	(None)
Default Value	0
Examples	STAT:OPER:ENAB 1312 STAT:OPER:ENAB 1 STATUS:OPERATION:ENABLE?
Query Syntax	STATus:OPERation:ENABLE?
Returned Parameters	<NR1> (Register value)
Related Commands	STAT:OPER:EVEN

STAT:OPER NTR/PTR Commands

These commands set or read the value of the Operation NTR (Negative-Transition) and PTR (Positive-Transition) registers. These registers serve as polarity filters between the Operation Enable and Operation Event registers to cause the following actions:

- When a bit in the Operation NTR register is set to 1, then a 1-to-0 transition of the corresponding bit in the Operation Condition register causes that bit in the Operation Event register to be set.
- When a bit of the Operation PTR register is set to 1, then a 0-to-1 transition of the corresponding bit in the Operation Condition register causes that bit in the Operation Event register to be set.
- If the same bits in both NTR and PTR registers are set to 1, then *any transition* of that bit at the Operation Condition register sets the corresponding bit in the Operation Event register.
- If the same bits in both NTR and PTR registers are set to 0, then *no transition* of that bit at the Operation Condition register can set the corresponding bit in the Operation Event register.

Note Setting a bit in the value of the PTR or NTR filter can of itself generate positive or negative events in the corresponding Operation Event register.

Command Syntax	STATus:OPERtion:NTRansition <NRf> STATus:OPERtion:PTRansition <NRf>
Parameters	0 to 32727
Suffix	(None)
Default Value	0
Examples	STAT:OPER:NTR 32 STAT:OPER:PTR 1312
Query Syntax	STAT:OPER:NTR? STAT:OPER:PTR?
Returned Parameters	<NR1> (Register value)
Related Commands	STAT:OPER:ENAB

STAT:PRES

This command sets all defined bits in the Status Subsystem PTR registers and clears all bits in the subsystem NTR and Enable registers. STAT:OPER:PTR is set to 1313 and STAT:QUES:PTR is set to 1555.

Command Syntax	STATus:PRESet
Parameters	(None)
Examples	STAT:PRES STATUS:PRESET
Query Syntax	(None)
Related Commands	(None)

Status Questionable Registers

Bit Configuration of Questionable Registers

Bit Position	15-11	10	9	8	7	6	5	4	3	2	1	0
Condition	NU	UNR	RI	NU	NU	NU	NU	OT	NU	NU	OC	OV
Bit Weight		1024	512	256	128	64	32	16	8	4	2	1

NU = (Not used); OC = Overcurrent protection circuit has tripped.
OT = Overtemperature status condition exists; OV = Overvoltage protection circuit has tripped.
RI = Remote inhibit is active; UNR = Power supply output is unregulated.
Note: See "Chapter 4 - Status Reporting" for more explanation of these registers.

STAT:QUES?

This query returns the value of the Questionable Event register. The Event register is a read-only register which holds (latches) all events that are passed by the Questionable NTR and/or PTR filter. Reading the Questionable Event register clears it.

Query Syntax	STATus:QUESTionable[:EVENT]?
Parameters	(None)
Returned Parameters	<NR1> (Register Value)
Examples	STAT:QUES? STATUS:QUESTIONABLE:EVENT?
Related Commands	*CLS STAT:QUES:ENAB STAT:QUES:NTR STAT:QUES:PTR

STAT:QUES:COND?

This query returns the value of the Questionable Condition register. That is a read-only register which holds the real-time (unlatched) questionable status of the power supply.

Query Syntax	STATus:QUESTionable:CONDition?
Parameters	(None)
Examples	STAT:QUES:COND? STATUS:QUESTIONABLE:CONDITION?
Returned Parameters	<NR1> (Register value)
Related Commands	(None)

STAT:QUES:ENAB

This command and its query set and read the value of the Questionable Enable register. This register is a mask for enabling specific bits from the Questionable Event register to set the questionable summary bit (QUES) of the Status Byte register. This bit (bit 3) is the logical OR of all the Questionable Event register bits that are enabled by the Questionable Status Enable register.

Command Syntax	STATus:QUESTIONable:ENABLE <NRf>
Parameters	0 to 32727
Suffix	(None)
Default Value	0
Examples	STAT:QUES:ENAB 20 STAT:QUES:ENAB 16
Query Syntax	STATus:QUESTIONable:ENABLE?
Returned Parameters	<NR1> (Register value)
Related Commands	STAT:QUES?

STAT:QUES NTR/PTR Commands

These commands allow you to set or read the value of the Questionable NTR (Negative-Transition) and PTR (Positive-Transition) registers. These registers serve as polarity filters between the Questionable Enable and Questionable Event registers to cause the following actions:

- When a bit of the Questionable NTR register is set to 1, then a 1-to-0 transition of the corresponding bit of the Questionable Condition register causes that bit in the Questionable Event register to be set.
- When a bit of the Questionable PTR register is set to 1, then a 0-to-1 transition of the corresponding bit in the Questionable Condition register causes that bit in the Questionable Event register to be set.
- If the same bits in both NTR and PTR registers are set to 1, then *any transition* of that bit at the Questionable Condition register sets the corresponding bit in the Questionable Event register.
- If the same bits in both NTR and PTR registers are set to 0, then *no transition* of that bit at the Questionable Condition register can set the corresponding bit in the Questionable Event register.

Note Setting a bit in the PTR or NTR filter can of itself generate positive or negative events in the corresponding Questionable Event register.

Command Syntax	STATus:QUESTIONable:NTRansition <NRf> STATus:QUESTIONable:PTRansition <NRf>
Parameters	0 to 32727
Suffix	(None)
Default Value	0
Examples	STAT:QUES:NTR 16 STATUS:QUESTIONABLE:PTR 512
Query Syntax	STAT:QUES:NTR? STAT:QUES:PTR?
Returned Parameters	<NR1> (Register value)
Related Commands	STAT:QUES:ENAB

SYST:ERR?

This query returns the next error number followed by its corresponding error message string from the remote programming error queue. The queue is a FIFO (first-in, first-out) buffer that stores errors as they occur. As it is read, each error is removed from the queue. When all errors have been read, the query returns **0,NO ERROR**. If more errors are accumulated than the queue can hold, the last error in the queue will be **-350,TOO MANY ERRORS** (see Table 5-1 in "Chapter 5 - Error Messages" for other error codes).

You can use the power supply front panel **Error** key to read errors from the queue. Errors generated at the front panel are not put into the queue but appear immediately on the display.

Query Syntax	SYSTem:ERRor?
Parameters	(None)
Returned Parameters	<NRI>,<SRD>
Examples	SYST:ERR? SYSTEM:ERROR?
Related Commands	(None)

SYST:LANG

This command switches the interface between its SCPI (TMSL) command language and its compatibility language. The compatibility language is provided for emulation of older power supply systems and is described in Appendix B. Sending the command causes:

- The alternate language to become active and to be stored in nonvolatile memory.
- The power supply to reset to the state stored in Location 0.

If the power supply is shut off, it will resume operation in the last-selected language when power is restored.

Command Syntax	SYSTem:LANGUage <string> <i>Syntax is the same, regardless of the present language.</i>
Parameters	TMSL COMPatibility Note: Parameter TMSL must be used in place of <i>SCPI</i> . <i>TMSL or last selected language.</i>
Default Value	<i>TMSL or last selected language.</i>
Examples	SYST:LANG TMSL SYSTEM:LANGUAGE COMPATIBILITY
Query Syntax	SYSTem:LANGUage?
Returned Parameters	<CRD> TMSL COMP
Related Commands	(None)

SYST:VERS?

This query returns the SCPI version number to which the power supply complies. The returned value is of the form YYYY.V, where YYYY represents the year and V is the revision number for that year.

Subsystem

Query Syntax	SYSTem:VERSion?
Parameters	(none)
Returned Parameters	<NR2>
Examples	SYST:VERS? SYSTEM:VERSION?
Related Commands	(None)

Trigger Subsystem

This subsystem controls remote triggering of the power supply.

TRIG

When the trigger subsystem is enabled, **TRIG** generates a trigger signal. The trigger will then:

1. Initiate a pending level change as specified by **CURR[:LEV]:TRIG** or **VOLT[:LEV]:TRIG**.
2. Clear the WTG bit in the Status Operation Condition register.
3. If **INIT:CONT** has been given, the trigger subsystem is immediately re-enabled for subsequent triggers. As soon as it is cleared, the WTG bit is again set to 1.

Command Syntax	TRIGger[:IMMediate]
Parameters	(None)
Examples	TRIG TRIGGER:IMMEDIATE
Query Syntax	(None)
Related Commands	ABOR CURR:TRIG INIT *TRG VOLT:TRIG

TRIG:SOUR

This command selects the trigger source. Since the power supply has no other trigger source than the GPIB bus, this command need not be used. It is included in the command set to provide programming compatibility with other instruments (such as the Agilent Electronic Load family) that may have more than one trigger source.

Command Syntax	TRIGger:SOURce <CRD>
Parameters	BUS
*RST Value	BUS
Examples	TRIG:SOUR BUS TRIGGER:SOURCE BUS
Query Syntax	TRIGger:SOURce?
Returned Parameters	<i>BUS</i>
Related Commands	*RST *TRG TRIG[:IMM]

Voltage Subsystem

This subsystem programs the output voltage of the power supply.

VOLT

VOLT:TRIG

These commands set the immediate voltage level or the pending triggered voltage level of the power supply. The immediate level is the voltage programmed for the output terminals. The pending triggered level is a stored voltage value that is transferred to the output terminals when a trigger occurs. A pending triggered level is unaffected by subsequent **VOLT** commands and remains in effect until the trigger subsystem receives a trigger or an **ABORT** command is given. If there is no pending **VOLT:TRIG** level, then the query form returns the **VOLT** level. In order for **VOLT:TRIG** to be executed, the trigger subsystem must be initiated (see **INITiate**).

Command Syntax	[SOURce]:VOLTage[:LEVel][:IMMediate][:AMPLitude] <NRf+> [SOURce][:VOLTage[:LEVel]:TRIGgered[:AMPLitude] <NRf+>
Parameters	Table 3-1
Default Suffix	V
*RST Value	Table 3-1
Examples	VOLT 200 MA VOLTAGE:LEVEL 200 MA VOLTAGE:LEVEL:IMMEDIATE:AMPLITUDE 2.5 VOLT:TRIG 20 VOLTAGE:LEVEL:TRIGGERED 20
Query Syntax	[SOURce]:VOLTage[:LEVel][:IMMediate][:AMPLitude]? [SOURce]:VOLTage[:LEVel][:IMMediate][:AMPLitude]? MAX [SOURce]:VOLTage[:LEVel][:IMMediate][:AMPLitude]? MIN [SOURce]:VOLTage[LEVel]:TRIGgered[:AMPLitude]? [SOURce]:VOLTage[LEVel]:TRIGgered[:AMPLitude]? MAX [SOURce]:VOLTage[:LEVel]:TRIGgered[:AMPLitude]? MIN
Returned Parameters	<NR3> VOLT? and VOLT:TRIG? return presently programmed immediate and triggered levels. If not triggered level is programmed, both returned values are the same. VOLT? MAX and VOLT? MIN return the maximum and minimum programmable immediate voltage levels. VOLT:TRIG? MAX and VOLT:TRIG? MIN return the maximum and minimum programmable triggered voltage levels.
Related Commands	For VOLT *SAV *RCL *RST For VOLT:TRIG ABOR VOLT *RST

VOLT:PROT

This command sets the overvoltage protection (OVP) level of the power supply. If the output voltage exceeds the OVP level, then the power supply output is disabled and the Questionable Condition status register OV bit is set (see "Chapter 4 - Status Reporting"). An overvoltage condition can be cleared with the **OUTP:PROT:CLE** command after the condition that caused the OVP trip is removed. The OVP always trips with zero delay and is unaffected by the **OUTP:PROT:DEL** command.

Command Syntax	[SOURce]:VOLTage:PROTection[:LEVel] <NRf+>
<i>*Alternate Syntax</i>	[SOURce]:VOLTage:PROTection:AMPLitude <NRf+>
Parameters	Table 3-1
Default Suffix	V
*RST Value	MAX
Examples	VOLT:PROT 21.5 VOLT:PROT:LEV MAX VOLTAGE:PROTECTION:LEVEL 145E-1
Query Syntax	[SOURce]:VOLTage:PROTection[:LEVel]? [SOURce]:VOLTage:PROTection [:LEVel]? MIN [SOURce]:VOLTage:PROTection [:LEVel]? MAX
Returned Parameters	<NR3> VOLT:PROT? returns presently programmed OVP level. VOLT:PROT? MAX and VOLT:PROT? MIN return the maximum and minimum programmable OVP levels.
Related Commands	OUTP:PROT:CLE *RST *SAV *RCL
	* Available to accommodate earlier power supply programs.

Command Summary

This summary lists all power supply subsystem commands in alphabetical order, followed by all common commands in alphabetical order. See Table 3-1 for the command parameters accepted by each power supply model.

Command Summary

Command	Parameters
	Subsystem Commands
ABOR	(none)
CAL	(See Appendix A in the Operating Manual)
[SOUR]:CURR[:LEV][:IMM][:AMPL]	<NRf+>[suffix]
[SOUR]:CURR[:LEV][:IMM][:AMPL]?	(none) MIN MAX
[SOUR]:CURR[:LEV]:TRIG[:AMPL]	<NRf+>[suffix]
[SOUR]:CURR[:LEV]:TRIG[:AMPL]?	(none) MIN MAX
[SOUR]:CURR:PROT:STAT	0 1 ON OFF
(SOUR):CURR:PROT:STAT?	(none)
[SOUR]:DIG:DATA[:VAL]	<NRf>
[SOUR]:DIG:DATA[:VAL]?	(none)
DISP(WIND):MODE	NORM TEXT
DISP(WIND):MODE?	(none)
DISP[:WIND][:STAT]	0 1 OFF ON
DISP[:WIND][:STAT]?	(none)
DISP[:WIND]:TEXT[:DATA]	<STR>
DISP[:WIND]:TEXT[:DATA]?	(none)
INIT[:IMM]	(none)
INIT:CONT	0 1 OFF ON
INIT:CONT?	(none)

Command Summary

Command	Parameters
Subsystem Commands	
MEAS:CURRENDC? MEAS:VOLTDC?	(none) (none)
OUTP[:STAT] OUTP[:STAT]? OUTP:PROT:CLE OUTP:PROT:DEL OUTP:PROT:DEL? OUTP:REL[:STAT] OUTP:REL[:STAT]? OUTP:REL:POL OUTP:REL:POL?	0 1 OFF ON (none) (none) 0 to 32.767 MIN MAX (none) MIN MAX 0 1 2OFF ON+ (none) NORM REV (none)
STAT:OPER:COND? STAT:OPER:ENAB STAT:OPER:ENAB? STAT:OPER[:EVEN]? STAT:OPER:NTR STAT:OPER:NTR? STAT:OPER:PTR STAT:OPER:PTR? STAT:PRES STAT:QUES:COND? STAT:QUES:ENAB STAT:QUES:ENAB? STAT:QUES[:EVEN]?	(none) <NRf> (none) (none) <NRf> (none) <NRf> (none) <NRf> (none) <NRf> (none) <NRf> (none) <NRf> (none) <NRf> (none) (none)
SYST:ERR? SYST:LANG SYST:LANG? SYST:VERS?	(none) TMSLICOMP (none) (none)
TRIG[:IMM] TRIG:SOUR TRIG:SOUR?	(none) BUS (n one)
[SOUR]:VOLT[:LEV][:IMM][:AMPL] (SOUR):VOLT[:LEV][:IMM][:AMPL]? [SOUR]:VOLT[:LEV]:TRIG[:AMPL] (SOUR):VOLT[:LEV]:TRIG[:AMPL]? [SOUR]:VOLT:PROT[:LEV] [SOUR]:VOLT:PROT[:LEV]?	<NRf+>[suffix] (none) MIN MAX <NRf+>[suffix] (none) MIN MAX <NRf+>[suffix] <NRf+>[suffix]

Common Commands

Command	Parameters
*CLS	(None)
*ESE	<NRf>
*ESE?	(None)
*ESR?	(None)
*IDN?	(None)
*OPC	(None)

Command	Parameters
*OPC?	(None)
*PSC	<bool>
*PSC?	(None)
*RCL	<NRf>
*RST	(None)
*SAV	<NRf>

Command	Parameters
*SRE	<NRf>
*SRE?	(None)
*STB?	(None)
*TRG	(None)
*TST?	(None)
*WAI	(None)

Programming Parameters

Table 3-1 list the programming parameters for each of the models.

Table 3-1. Power Supply Programming Parameters (see note)

Parameter	Agilent Model and Value				
CURR[:LEV] MAX and CURR[:LEV]:TRIG MAX (Programming range is 0 to MAX)	<u>6641A</u>	<u>6642A</u>	<u>6643A</u>	<u>6644A</u>	<u>6645A</u>
	20.475 A	10.237 A	6.142 A	3.583 A	1.535 A
	<u>6651A</u>	<u>6652A</u>	<u>6653A</u>	<u>6654A</u>	<u>6655A</u>
	51.188 A	25.594 A	15.356 A	9.214 A	4.095 A
	<u>6671A</u>	<u>6672A</u>	<u>6673A</u>	<u>6674A</u>	<u>6675A</u>
	225.23 A	102.37 A	61.43 A	35.83 A	18.43 A
	<u>6680A</u>	<u>6681A</u>	<u>6682A</u>	<u>6683A</u>	<u>6684A</u>
	875 A	580 A	240 A	160 A	128 A
*RST Current Value	<u>6641A</u>	<u>6642A</u>	<u>6643A</u>	<u>6644A</u>	<u>6645A</u>
	0.08 A	0.04 A	0.024 A	0.014 A	0.006 A
	<u>6651A</u>	<u>6652A</u>	<u>6653A</u>	<u>6654A</u>	<u>6655A</u>
	0.205 A	0.100 A	0.060 A	0.036 A	0.016 A
	<u>6671A</u>	<u>6672A</u>	<u>6673A</u>	<u>6674A</u>	<u>6675A</u>
	0.88 A	0.40 A	0.24 A	0.14 A	0.07 A
	<u>6680A</u>	<u>6681A</u>	<u>6682A</u>	<u>6683A</u>	<u>6684A</u>
	73.71 A	48.75 A	20.26 A	13.51 A	10.79 A
OUTP:PROT:DEL *RST Value	0 to 32.727 s (MAX) for all models 200 ms for all models				
VOLT[:LEV] MAX and VOLT[:LEV]:TRIG MAX (Programming range is 0 to MAX)	<u>6641A</u>	<u>6642A</u>	<u>6643A</u>	<u>6644A</u>	<u>6645A</u>
	<u>6651A</u>	<u>6652A</u>	<u>6653A</u>	<u>6654A</u>	<u>6655A</u>
	<u>6671A</u>	<u>6672A</u>	<u>6673A</u>	<u>6674A</u>	<u>6675A</u>
	8.190 v	20.475 V	35.831 V	61.425 V	122.85 V
	<u>6680A</u>	<u>6681A</u>	<u>6682A</u>	<u>6683A</u>	<u>6684A</u>
	5.145 V	8.190 V	21.50 V	32.75 V	41.0 V
*RST Voltage Value	0 V for all models				
VOLT:PROT MAX (Programming range is 0 to MAX)	<u>6641A</u>	<u>6642A</u>	<u>6643A</u>	<u>6644A</u>	<u>6645A</u>
	<u>6651A</u>	<u>6652A</u>	<u>6653A</u>	<u>6654A</u>	<u>6655A</u>
	8.8 V	22.0 V	38.5 V	66.0 V	132.0 V
	<u>6671A</u>	<u>6672A</u>	<u>6673A</u>	<u>6674A</u>	<u>6675A</u>
	10.0 V	24.0 V	42.0 V	72.0 V	144.0 V
	<u>6680A</u>	<u>6681A</u>	<u>6682A</u>	<u>6683A</u>	<u>6684A</u>
	6.25 V	10.0 V	25.2 V	38.4 V	48.0 V
*RST OVP value	MAX for all models				

Note For programming accuracy and resolution, see the Specifications and Supplemental Characteristics in the Operating Guide.

Status Reporting

Power Supply Status Structure

Figure 4-1 shows the status register structure of the power supply. The Standard Event, Status Byte, and Service Request Enable registers and the Output Queue perform standard GPIB functions as defined in the *IEEE 488.2 Standard Digital Interface for Programmable Instrumentation*. The Operation Status and Questionable Status registers implement status functions specific to the power supply. Table 4-2 and Figure 4-1 show the bit configuration of each status register.

Operation Status Group

Register Functions

The Operation Status registers record signals that occur during normal operation. The group consists of the following registers:

- A Condition register that holds real-time status of the circuits being monitored. It is a read-only register.
- A PTR/NTR (positive transition/negative transition) Filter that functions as described under **STAT:OPER:NTR|PTR COMMANDS** in "Chapter 3 - Language Dictionary". This is a read/write register.
- An Event register that latches any condition that is passed through the PTR or NTR filters. Reading the Event register clears it.
- An Enable register that functions as described under **STAT:OPER:ENAB** in "Chapter 3 - Language Dictionary". This is a read/write register.

The outputs of the Operation Status group are logically-ORed into the OPER(ation) summary bit (7) of the Status Byte register.

Register Commands

Commands that access this group are derived from the **STAT:OPER** commands described in "Chapter 3 - Language Dictionary" and summarized in Table 4-1.

Table 4-1. Status Operation Commands

Register	Command	Query	Cleared By
Condition	(None)	STAT:OPER:COND?	Cannot be cleared
PTR Filter	STAT:OPER:PTR <NRf>	STAT:OPER:PTR?	Programming 0
NTR Filter	STAT:OPER:NTR <NRf>	STAT:OPER:NTR?	Programming 0 or STAT:PRES
Event	(None)	STAT:OPER:EVEN?	Reading or *CLS
Enable	STAT:OPER:ENAB <NRf>	STAT:OPER:ENAB?	Programming 0

Table 4-2. Bit Configurations of Status Registers

Bit	Signal	Meaning	Bit	Signal	Meaning
Operation Status Group					
0	CAL	The interface is computing new calibration constants.	0	OPC	Operation complete.
5	WTG	The interface is waiting for a trigger.	2	QYE	Query error.
8	CV	The power module is in constant voltage mode.	3	DDE	Device-dependent error.
10	CC	The power module is in constant current mode.	4	EXE	Execution error.
Questionable Status Group					
0	OV	The power module overvoltage protection circuit has tripped.	5	CME	Command error.
1	OC	The power module overcurrent protection circuit has tripped.	7	PON	Power on.
4	OT	The power module has an overtemperature condition.	Status Byte and Service Request Enable Registers		
9	RI	The power module remote inhibit state is active.	3	QUES	Questionable status summary bit.
10	UNR	The power module output is unregulated.	4	MAV	Message Available summary bit.
			5	ESB	Event Status summary bit.
			6	MSS	Master Status summary bit.
			7	RQS	Request Service bit.
				OPER	Operation status summary bit.

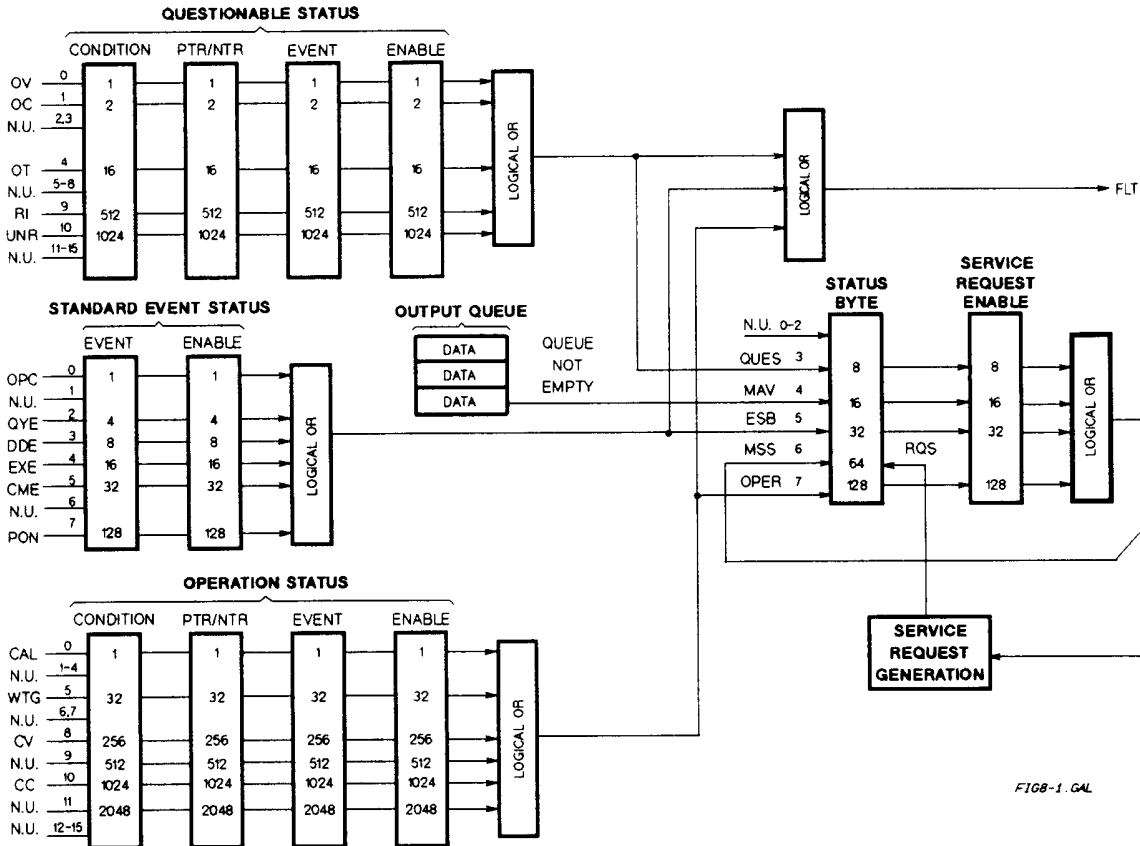

Figure 4-1. Power Supply Status Model

Questionable Status Group

Register Functions

The Questionable Status registers record signals that indicate abnormal operation of the power supply. As shown in Figure 4-1, the group consists of the same type of registers as the Status Operation group. The outputs of the Questionable Status group are logically-ORed into the QUES(tionable) summary bit (3) of the Status Byte register.

Register Commands

Programming for this group is derived from the **STAT:QUES** commands described in "Chapter 3 - Language Dictionary" and summarized in Table 4-3.

Table 4-3. Status :Questionable Commands

Register	Command	Query	Cleared By
Condition	(None)	STAT:QUES:COND?	Cannot be cleared
PTR Filter	STAT:QUES:PTR <NRf>	STAT:QUES:PTR?	Programming 0
NTR Filter	STAT:QUES:NTR <NRf>	STAT:QUES:NTR?	Programming 0 or STAT:PRES
Event	(None)	STAT:QUES:EVEN?	Reading or *CLS
Enable	STAT:QUES:ENAB <NRf>	STAT:QUES:ENAB?	Programming 0

Standard Event Status Group

Register Functions

This group consists of an Event register and an Enable register that are programmed by common commands. The Standard Event Status Event register latches events relating to interface communication status (see Table 4-1). It is a read-only register that is cleared when read.

Read query ***ESR!**
Cleared by ***CLS *ESR?**

The Standard Event Status Enable register functions similarly to the enable registers of the Operation and Questionable status groups.

Register Commands

The common ***ESE** command programs specific bits in the Standard Event Status Enable register. Because the power supply implements ***PSC**, the register is cleared at power on if ***PSC = 1**. ***ESR?** reads the Standard Event Status Event register and reading the register clears it.

Programmed by ***ESE <NRf>**
Read query ***ESE?**
Cleared by ***ESE 0**

STATUS BYTE REGISTER

This register summarizes the information from all other status groups as defined in the "IEEE 488.2 Standard Digital Interface for Programmable Instrumentation" standard. The bit configuration is shown in Table 4-1. The register can be read either by a serial poll or by ***STB?**. Both methods return the same data, except for bit 6. Sending ***STB?** returns **MSS** in bit 6, while poring the register returns **RQS** in bit 6.

The RQS Bit

Whenever the power supply requests service, it sets the SRQ interrupt line true and latches RQS into bit 6 of the Status Byte register. When the controller services the interrupt, RQS is cleared inside the register and returned in bit position 6 of the response. The remaining bits of the Status Byte register are not disturbed.

The MSS Bit

This is a real-time (unlatched) summary of all Status Byte register bits that are enabled by the Service Request Enable register. MSS is set whenever the power supply has at least one reason (and possibly more) for requesting service. Sending ***STB?** reads the MSS in bit position 6 of the response. No bits of the Status Byte register are cleared by reading it.

Determining the Cause of a Service Interrupt

You can determine the reason for an SRQ by the following actions:

- Use a serial poll or the ***STB?** query to determine which summary bits are active.
- Read the corresponding Event register for each summary bit to determine which events caused the summary bit to be set. When an Event register is read, it is cleared. This also clears the corresponding summary bit.
- The interrupt will recur until the specific condition that caused each event is removed. If this is not possible, the event may be disabled by programming the corresponding bit of the status group Enable register or NTR|PTR filter. A faster way to prevent the interrupt is to disable the service request by programming the appropriate bit of the Service Request Enable register.

Service Request Enable Register

This register is a mask that determines which bits from the Status Byte register will be ORed to generate a service request (SRQ). The register is programmed with the ***SRE** common command. When the register is cleared, no service requests can be generated to the controller.

Output Queue

The Output Queue is a first-in, first-out (FIFO) data register that stores power supply-to-controller messages until the controller reads them. Whenever the queue holds one or more bytes, it sets the MAV bit (4) of the Status Byte register. If too many unread error messages are accumulated in the queue, a system error message is generated (see Table 5-1 in "Chapter 5 - Error Messages"). The Output Queue is cleared at power on and by ***CLS**.

Initial Conditions At Power On

Status Registers

When the power supply is turned on, a sequence of commands initializes the status registers. For the factory-default ***RST** power-on state, Table 4-4 shows the register states and corresponding power-on commands.

Table 4-4. Default Power On Register States

Register	Condition	Caused By
Operation PTR; Questionable PTR	All bits = 1	STAT:PRE
Operation NTR; Questionable NTR	All bits = 0	STAT:PRE
Operation Event; Questionable Event	All bits = 0	*CLS
Operation Enable; Questionable Enable	All bits = 0	STAT:PRE
Standard Event Status Enable	All bits = 0 ¹	*ESE 0
Status Byte	All bits = 0	*CLS
Status Request Enable	All bits = 0 ¹	*SRE 0
Output Queue	Cleared	*CLS

¹If PSC=1. If PSC = 0, then the last previous state before turn on is recalled. The value of PSC is stored in nonvolatile memory.

The PON (Power-On) Bit

The PON bit in the Standard Event register is set whenever the power supply is turned on. The most common use for PON is to generate an SRQ at power on following an unexpected loss of power. To do this, bit 7 of the Standard Event Enable register must be set so that a power-on event registers in the ESB (Standard Event Summary Bit). Also, bit 5 of the Service Request Enable register must be set to permit an SRQ to be generated. The commands to accomplish these two conditions are:

***ESE 128**
***SRE 32**

If ***PSC** is programmed to **0**, the contents of the Standard Event Enable and Service Request Enable registers are saved in nonvolatile memory and recalled at power on. This allows a PON event to generate SRQ at power on. Programming ***PSC** to **1** prevents these registers from being saved and they are cleared at power on. This prevents a PON event from generating SRQ at power on.

Examples

Note These examples are generic SCPI commands. See "Chapter 2 - Remote Programming" for information about encoding the commands as language strings.

Servicing an Operation Status Mode Event

This example assumes you want a service request generated whenever the power supply switches to the CC (constant current) mode. From Figure 4-1, note that the required path is for a condition at bit 10 (CC) of the Operation Status register to set bit 6 (RQS) of the Status Byte register. The required register programming is shown in Table 4-5.

Table 4-5. Generating RQS from the CC Event

Register	Command	Comment
Operation PTR	STAT:OPER:PTR 1024	Allows a positive transition at the CC input (bit 10) to be latched into the Status Event register. ¹
Operation Enable	STAT:OPER:ENAB 1024	Allows the latched CC event to be summed into the OPER summary bit.
Service Request Enable	*SRE 128	Enables the OPER summary bit from the Status Byte register to generate RQS.
Operation Condition	STAT:OPER:EVEN?	When you service the request, read the event register to determine that bit 10 (CC) is set and to clear the register for the next event.
¹ All bits of the PTR registers bits are set to 1 at power on or in response to STAT:PRES .		

Adding More Operation Events

To add the CV (constant voltage) event to this example, it is only necessary to add the decimal values for bit 8 (value 64) to the programming commands of the Operation Status group. The commands to do this are:

STAT:OPER:PTR 1280;ENAB 1280

It is not necessary to change any other registers, since the programming for the operation summary bit (OPER) path has already been done.

Servicing Questionable Status Events

To add OC (overcurrent) and OT (overtemperature) events to this example, program Questionable Status group bits 1 and 4.

STAT:QUES:PTR 18;ENAB 18

Next, you must program the Service Request Enable register to recognize both the questionable (QUES) and the operational (OPER) summary bits.

***SRE 136**

Now when there is a service request, read back both the operational and the questionable event registers.

STAT:OPER:EVEN?;QUES:EVEN?

Monitoring Both Phases of a Status Transition

You can monitor a status signal for both its positive and negative transitions. For example, to generate RQS when the power supply either enters the CC (constant current) condition or leaves that condition, program the Operational Status PTR/NTR filter as follows:

**STAT:OPER:PTR 1024;NTR 1024
STAT:OPER:ENAB 1024;*SRE 128**

The PTR filter will cause the OPER summary bit to set RQS when CC occurs. When the controller subsequently reads the event register (**STAT: OPER: EVEN?**), the register is cleared. When CC subsequently goes false, the NTR filter causes the OPER summary bit to again set RQS.

SCPI Command Completion

SCPI commands sent to the power supply are processed either sequentially or in parallel. Sequential commands finish execution before a subsequent command begins. A parallel command can begin execution while a preexisting command is still executing (overlapping commands). Commands that affect trigger actions are among the parallel commands.

The ***WAI**, ***OPC**, and ***OPC?** common commands provide different ways of indicating when all transmitted commands, including any parallel ones, have completed their operations. The syntax and parameters for these commands are described in "Chapter 3 - Language Dictionary". Some practical considerations for using these commands are as follows:

- *WAI** This prevents the power supply from processing subsequent commands until all pending operations are completed. If something prevents completion of an existing operation, ***WAI** can place the power supply and the controller in a "hang- up" condition.
- *OPC?** This places a 1 in the Output Queue when all pending operations have completed. Because it requires your program to read the returned value from the queue before executing the next program statement, ***OPC?** could prevent subsequent commands from being executed.
- *OPC** This sets the OPC status bit when all pending operations have completed. Since your program can read this status bit on an interrupt basis, ***OPC** allows subsequent commands to be executed.

The trigger subsystem must be in the Idle state in order for the status OPC bit to be true. Therefore, as far as triggers are concerned, OPC is false whenever the trigger subsystem is in the Initiated state. However, OPC is also false if there are any commands still pending.

Note For a detailed discussion of ***WAI**, ***OPC** and ***OPC?**, see "Device/Controller Synchronization Techniques" in ANSI/IEEE Std 488.2.

DFI (Discrete Fault Indicator)

Whenever a fault is detected in the power supply, it is capable of generating a FLT signal at the digital port (see "Appendix D - Digital Port Functions" in the power supply Operating Guide). The source for the DFI signal can be any Questionable, Operation, or Standard Event status event (see Figure 4-1).

RI (Remote Inhibit)

Whenever a remote inhibit signal is received at the digital port (see "Appendix D - Digital Port Functions" in the power supply Operating Guide), the power supply will receive an RI event at the Questionable Status register. By programming the status subsystem, you may use RI to generate a service request (SRQ) to the controller and/or to create a DFI output at the digital port. By using RI/DFI in this way, you can chain the power supplies to create a serial shutdown in response to the INH input.

Error Messages

Power Supply Hardware Error Messages

Front panel error messages resulting from selftest errors or runtime failures are described in “Chapter 3 - Turn-On Checkout” of the power supply Operating Guide.

Calibration Error Messages

Front panel error messages resulting from calibration errors are described in Appendix A of the power supply Operating Guide.

System Error Messages

System error messages are obtained remotely with the **SYST:ERR?** query or by pressing the front panel **Error** key. The error number is the value placed in the error queue. **SYST:ERR?** returns the error number into a variable and combines the number and the error message into a string. Table 5-1 lists the system errors that are associated with SCPI syntax errors and with interface problems. Information inside the brackets is not part of the standard error message, but is included for clarification. When system errors occur, the Standard Event Status register (see "Chapter 4 - Status Reporting") records them as follows:

Standard Event Status Register Error Bits

Bit Set	Error Code	Error Type	Bit Set	Error Code	Error Type
5	-100 thru -199	Command	3	-300 thru -399	Device-dependent
4	-200 thru -299	Execution	2	-400 thru -499	Query

Table 5-1. Summary of System Error Messages

Error Number	Error String [Description/Explanation/Examples]
-100	Command error [generic command error]
-101	Invalid character
-102	Syntax error [unrecognized command or data type]
-103	Invalid separator [illegal character encountered in place of separator]
-104	Data type error [e.g., “numeric or string expected, got block date”]
-105	GET not allowed [<GET> inside a program message]
-108	Parameter not allowed [too many parameters]
-109	Missing parameter [too few parameters]
-112	Program mnemonic too long [maximum 12 characters]
-113	Undefined header [syntactical correct but not defined for this device]
-121	Invalid character in number [e.g. alpha in decimal data, etc.]
-123	Exponent too large [numeric overflow; exponent magnitude >32000]
-124	Too many digits [number too long; more than 255 digits received]
-128	Numeric data not allowed [numeric data not accepted where positioned]
-131	Invalid suffix [unrecognized suffix, or suffix not appropriate]
-138	Suffix not allowed [numeric element does not allow suffixes]

Table 6-1. Summary of System Error Messages (continued)

Error Number	Error String [Description/Explanation/Examples]
-141	Invalid character data [bad character, or unrecognized]
-144	Character data too long [maximum length is 12 characters]
-148	Character data not allowed [character data not accepted where positioned]
-150	String data error [generic string error]
-151	Invalid string data [e.g., END received before close quote]
-158	String data not allowed [string data not accepted where positioned]
-160	Block data error [generic data block error]
-161	Invalid block data [e.g., END received before length satisfied]
-168	Block data not allowed [block data not accepted where positioned]
-220	Parameter error
-221	Settings conflict [uncoupled parameters]
-222	Data out of range [e.g., outside the range of this device]
-223	Too much data [out of memory; block, string, or expression too long]
-240	Hardware error [device-dependent]
-241	Hardware missing [device-dependent]
-310	System error [device-dependent]
-313	Calibration memory lost [out of calibration due to memory failure]
-330	Self-test failed [more specific data after “;”]
-350	Queue overflow [errors lost due to too many errors in queue]
-400	Query error [generic query error]
-410	Query INTERRUPTED [query followed by DAB or GET before response complete]
-420	Query UNTERMINATED [addressed to talk, incomplete programming message received]
-430	Query DEADLOCKED [too many queries in command string]
-440	Query UNTERMINATED [query received after query for indefinite response]

SCPI Conformance Information

Note See *Chapter 3 - Language Dictionary* for command syntax.

SCPI Version

This power supply conforms to Version 1990.0.

SCPI Confirmed Commands¹

ABOR	OUTP:PROT:DEL	TRIG[:STAR]:DEL
CAL[:STAT]	OUTP:PROT:DEL?	TRIG[:STAR]:DEL?
[SOUR]:CURR[:LEV][:IMM][:AMPL]	STAT:OPER[:EVEN]?	TRIG[:STAR]:SOUR
[SOUR]:CURR[:LEV][:IMM][:AMPL]	STAT:OPER:COND?	TRIG[:STAR]:SOUR?
?		
(SOUR):CURR[:LEV]:TRIG[:AMPL]	STAT:OPER:ENAB	[SOUR]:VOLT[:LEV][:IMM][:AMPL]
(SOUR):CURR[:LEV]:TRIG[:AMPL]?	STAT:OPER:ENAB?	[SOUR]:VOLT[:LEV][:IMM][:AMPL]?
[SOUR]:CURR:PROT:STAT	STAT:OPER:NTR	[SOUR]:VOLT[:LEV]:TRIG[:AMPL]
[SOUR]:CURR:PROT:STAT?	STAT:OPER:NTR?	[SOUR]:VOLT[:LEV]:TRIG[:AMPL]?
DISP[:WIND][:STAT]	STAT:OPER:PTR	[SOUR]:VOLT:PROT[:LEV]
DISP[:WIND][:STAT]?	STAT:OPER:PTR?	[SOUR]:VOLT:PROT[:LEV]?
DISP[:WIND]:TEXT[:DATA]	STAT:PRES	*CLS *RCL
DISP[:WIND]:TEXT[:DATA]?	STAT:QUES[:EVEN]?	*ESE *RST
INIT[:IMM]	STAT:QUES:COND?	*ESE? *SAV
INIT:CONT	STAT:QUES:ENAB	*ESR? *SRE
INIT:CONT?	STAT:QUES:ENAB?	*IDN? *SRE?
MEAS:CURR[:DC]?	SYST:ERR?	*OPC *STB?
MEAS:VOLT[:DC]?	SYST:LANG	*OPC? *TRG
OUTP[:STAT]	SYST:LANG?	*PSC *TST?
OUTP[:STAT]?	SYST:VERS?	*PSC? *WAI
OUTP:PROT:CLE	TRIG[:STAR][:IMM]	

¹See *Appendix A - Calibration* in the Operating Guide for CAL commands.

SCPI Approved Commands

(None)

NON-SCPI Commands¹

CAL:CURR[:DATA]	CAL:VOLT:LEV	OUTP:REL:POL
CAL:CURR:LEV	CAL:VOLT:PROT	OUTP:REL:POL?
CAL:CURR:MON	[SOUR]:DIG:DATA[:VAL]	OUTP:REL[:STAT]
CAL:PASS	[SOUR]:DIG:DATA[:VAL]?	OUTP:REL[:STAT]?
CAL:SAV	DISP[:WIND]:MODE	[SOUR]:VOLT:PROT[:AMPL]
CAL:VOLT[:DATA]	DISP[:WIND]:MODE?	[SOUR]:VOLT:PROT[:AMPL]?

¹See *Appendix A* - Calibration in the Operating Guide for **CAL** commands.

Compatibility Language

The Agilent Series 664xA, 665xA, 667xA, and 668xA Power Supplies are programatically compatible with the Agilent 603xA Series AutoRanging Power Supplies (ARPS). This means that you can program the Agilent 664xA, 665xA, 667xA, and 668xA supplies over the GPIB using the ARPS commands. Software that you have written for the autoranging power supplies can also be adapted to program the above supplies.

Note The Agilent 664xA, 665xA, 667xA, and 668xA serial link is not supported by ARPS commands. You can use only a GPIB primary address for the power supply.

To switch from SCPI commands to ARPS commands (and vice versa), use the SYST:LANG command. This command is documented in "Chapter 3 - Language Dictionary".

Table B-1 summarizes the ARPS commands that program the supplies. You will need to refer to the Series 603xA power supply manual¹ for complete information on the ARPS commands. Some of the ARPS commands are similar to SCPI commands, but others are unique to ARPS. For example, the ARPS FOLD commands have no function with the Series 664xA, 665xA, 667xA, and 668xA supplies. Similarly, there are some SCPI commands that have no ARPS function.

Note **Parallel Polling:**
When programmed for parallel polling and Compatibility Language, power supplies operating under the Agilent BASIC system can "hang up" the GPIB when the system is turned on. This can occur under the following conditions:

- The controller uses CS80 Protocol for an external disk drive (for example, the Agilent 9133D).
- The external disk drive and the power supply have the same *select code* and *that code is 7 or less*.
- The external disk drive and power supply addresses are binary complements of each other (e.g., 0 & 7, 1 & 6, etc.).

When the system is turned on, the power supply accesses the GPIB before the controller and prevents it from accessing the external disk drive. The solution is to change one of the GPIB addresses, or to ensure that the power supply is not turned on until after the controller has completed its selftest and has control of the GPIB.

¹ This manual is listed in the Chapter 1 "Replaceable Parts" table of the power supply Operating Guide.

Table B-1. ARPS Commands

ARPS Command¹	Description	Similar SCPI Command
VSET x VSET xV VSET xMV	These commands program output voltage. See Table 3-1 for the programming ranges of these commands. Initial condition: 0 V	VOLT
ISET x ISET xA ISET xMA	These commands program output current. See Table 3-1 for the programming ranges for these commands. Initial condition: 0 A	CURR
VSET? ISET?	These commands read voltage or current settings.	VOLT? CURR?
VOUT? IOUT?	These commands measure and read output voltage or current.	MEAS:VOLT? MEAS:CURR?
OVP x OVP xV OVP xMV	NOTE: OVP commands do not work with Agilent 603xA supplies. These commands program the overvoltage protection. The OVP setting is programmed in either volts or millivolts. See Table 3-1 for the programming ranges of these commands. Initial condition: 10% above rated output.	VOLT:PROT
OVP?	This command reads the OVP setting.	VOLT:PROT?
VMAX x VMAX xV VMAX xMV	These commands program an upper limit (soft limit) to the voltage programming value that the power supply will accept. The programming ranges are the same as those used for VSET .	(None)
IMAX x IMAX xA IMAX xMA	These commands program an upper limit (soft limit) to the current programming value that the power supply will accept. The programming ranges are the same as those used for ISET .	(None)
VMAX? IMAX?	These commands read the soft voltage or current limits.	(None)
DLY x DLY xS DLY xMS	These commands program the delay time before a new output voltage or current is implemented or an RST , OUT ON , or CLR command is received. During the delay the CV, CC, and CR conditions cannot be reported as faults, and foldback protection is disabled.	OUTP:PROT:DEL
DLY?	This command reads the delay time setting.	OUTP:PROT:DEL?
OUT OFF OUT 0 OUT ON OUT 1	These commands enable or disable the power supply output. The disabled state programs the output to relatively low voltage and current values. The supply will be able to implement commands even while the output is disabled. Initial condition: OUT ON	OUTP:STAT OFF OUTP:STAT 0 OUTP:STAT ON OUTP:STAT 1
FOLD OFF FOLD CC FOLD 2 FOLD 0 FOLD CV FOLD 1 FOLD CC FOLD 2	These commands enable or disable Foldback protection. Foldback protection disables the power supply output if the power supply switches to whichever mode (CV or CC) is defined as the fold (error) condition. Note that foldback protection is disabled during the DELAY period. Initial condition: FOLD OFF	(None)
FOLD?	This command reads the Foldback setting.	(None)

¹ x = any digit (within range) MA = milliamperere MV = millivolt MS = millisecond.

Table B-1. ARPS Commands (continued)

ARPS Command ¹	Description	Similar SCPI Command
RST	This command resets the power supply if the output is disabled by the overvoltage, remote inhibit, or foldback protection circuits. The power supply resets to the parameters stored for the power-on state. Note that the settings can be changed while the supply is disabled.	OUTP:PROT:CLE
HOLD OFF HOLD 0 HOLD ON HOLD 1	These commands determine if certain newly received commands are immediately acted on by the power supply or are acted on later while the supply continues to operate with previously received values. HOLD ON can be used to synchronize power supply actions with the actions of other GPIB devices. (See the TRG command.) Initial condition: HOLD OFF	VOLT:TRIG CURR:TRIG
HOLD?	This command reads the HOLD setting.	VOLT:TRIG? CURR:TRIG?
T TRG	These commands cause the power supply to act on commands that have been previously sent, but are being held (pending). The supply continues to operate with previously received values until a trigger command is received (see HOLD command.) The device trigger interface message performs the same function.	INIT ON;TRIG INIT ON;*TRG
STO RCL	These commands cause the power supply to store and recall power supply states, except for output on/off. Each state includes: voltage (1st and 2nd rank), current (1st and 2nd rank), soft voltage and current limit, delay time, service request on/off, foldback (1st and 2nd rank), mask (1st and 2nd rank), and hold. Initial condition: Each register is initiated to the turn-on values.	*SAV *RCL
STS?	This command reads the contents of the status register, which maintains the present status of the power supply.	STAT:OPER:COND? STAT:QUES:COND? *ESE?
ASTS?	This command reads the contents of the accumulated status register, which stores any bit condition entered in the status register since the accumulated status register was last read, regardless of whether the condition still exists.	STAT:OPER? STAT:QUES? *ESE?
UNMASK mnemonics UNMASK xxx	These commands determine the conditions that will set bits in the fault register, allowing the operator to define the conditions that will be reported as faults. Fault conditions can be enabled by sending a string of status register mnemonics after the UNMASK command. The mnemonics must be separated by commas, and may be sent in any order, but must correspond to the condition that will be enabled. Fault conditions can also be enabled by sending the decimal equivalent of the total bit weight of all conditions to be enabled. UNMASK NONE disables all conditions from setting bits in the fault register. Initial condition: UNMASK NONE	STAT:OPER:ENAB STAT:QUES:ENAB *ESE

Table B-1. ARPS Commands (continued)

ARPS Command ¹	Description	Similar SCPI Command
UNMASK?	This command reads which bits in the status register have been enabled as fault conditions. The decimal equivalent of the total bit weight of all enabled bits is returned.	STAT:OPER:ENAB? STAT:QUES:ENAB? ESE
FAULT?	This command reads which bits have been set in the fault register. A bit is set in the fault register when the corresponding bit in the status register changes from inactive to active AND the corresponding bit in the mask register has been enabled. The fault register is reset only after it has been read. The decimal equivalent of the total bit weight of all enabled bits is returned.	STAT:OPER? STAT:QUES? *ESE
SRQ OFF SRQ 0 SR*Q ON SRQ 1	These commands enable or disable the power supply's ability to request service from the controller for fault conditions. UNMASK defines which conditions are defined as faults. Initial condition: SRQ OFF	*SRE
SRQ?	This command reads the SRQ setting.	*SRE?
CLR	This command initializes the power supply to the power-on state. It also resets the PON bit in the serial poll register. The command performs the same function as the Device Clear (DCL) interface message.	*RST
ERR?	This command determines the type of programming error detected by the supply. A remote programming error sets the ERR bit in the status register, which can be enabled by UNMASK to request service.	SYST:ERR?
TEST?	This command causes the power supply to run selftest and report any detected failures.	*TST?
ID?	This command causes the power supply to report its model number and any options that affect the supply's output.	*IDN?
SYST:LANG	This command causes the alternate language to become active and to be stored in nonvolatile memory. In this case, the commands are equivalent. After being shut off, the power supply will resume in the last-selected language when power is restored. The parameter must be either COMP or TMSL , not SCPI .	SYST:LANG

Index

A

<AARD>	15, 28
analog port (see "Chapter 4 - User Connections" in the User's Guide)	
analog programming (see "Chapter 4 - User Connections" in the User's Guide)	
ANSI/IEEE	8, 57
ARPS language.....	63

C

CAL bit (see status bit)	
calibration	
password (see "Appendix A - Calibration" in the User's Guide)	
procedure (see "Appendix A - Calibration" in the User's Guide)	
CC bit (see status bit)	
mode	17, 40, 56
common commands	10, 14, 25
*CLS	26-27, 32, 40, 42, 48, 51, 53, 54, 55, 61
*ESE	18, 27, 30, 48, 53, 55, 61, 65-66
*ESR?	18, 27-28, 48, 53, 61
*IDN?	28, 48, 61, 66
*OPC	28, 33, 48, 57, 61
*OPC?	29, 33, 48, 57, 61
*PSC	29-30, 31, 32, 48, 53, 55, 61
*RCL	17, 30, 31, 35, 36, 38, 39, 40, 48, 61, 65
*RST	30, 31, 35-36, 37, 38, 39, 45, 46, 48, 54, 61, 66
*SAV	17, 31, 35, 36, 38, 39, 40, 48, 61, 65
*SRE.....	17, 30, 32, 48, 55, 56, 61, 66
*STB?	27, 32-33, 48, 54, 61
*TRG	17, 29, 33, 35, 38, 47, 48, 61, 65
*TST?	33, 48, 61, 66
*WAI	29, 33, 57, 61
connector, digital port (see "Appendix D - Digital Port Functions" in the User's Guide)	
<CRD>	15, 37, 40, 44, 45
CV bit (see status bit)	

D

data	
boolean	15, 30, 35, 36, 38, 39, 48
character	15
multiplier	15
numerical	15
suffix.....	15
DCL command.....	12, 29, 33, 66
DDE bit (see status bit) default state (see *RST state)	
DFI.....	57
digital port	
electrical characteristics (see Table 1-5 in the User's Guide)	
electrical connections (see "Appendix D - Digital Port Functions" in the User's Guide)	
programming.....	18, 36

E

error queue	27, 60
error messages	
calibration (see "Appendix A - Calibration" in the User's Guide)	
hardware (see "Chapter 3 - Turn-On Checkout" in the User's Guide)	
runtime (see "Chapter 3 - Turn-On Checkout" in the User's Guide)	
selftest.....	33
system	59
ESB bit (see status bit)	
EXE bit (see status bit)	

F

factory-default state (see *RST state)	
FLT output (see DFI)	

G

<GET> command	33, 38, 59
GW-BASIC	20

H

hazard, energy.....	30
header (see SCPI header)	
Agilent BASIC.....	20
DOS driver.....	20
GPIB	
capabilities (see Table 1-5 in the User's Guide)	
connections (see "Chapter 4 - User Connections?" in the User's Guide)	
documents.....	7
GPIB address	18
HPSL	9

I

IEEE (see ANSI/IEEE)	
implied	
colon	13
decimal point	15
header (see header, optional)	
message terminator	15
INH input (see RI)	
interrupt	17, 54, 57

K

keyword (see header)

L

language, Compatibility (see ARPS language)

language, SCPI (see SCPI)

local lockout command 7

local sense switch ("Chapter 4 - User Connections" in the User's Guide)

M

manual

Series 603xA (see the User's Guide)

Operating Guide 7

SCPI 7

MAV bit (see status bit)

message

terminator 11, 12

unit 10

unit separator 11, 12

units, combining 10

message, error (see error messages)

MSS bit (see status bit)

N

National Instruments DOS driver 20

non-SCPI commands 62

nonvolatile memory 27, 30, 31, 32

<NR1> 15

<NR2> 15

<NR3> 15

<NRf> 15

<NRf+> 15

O

OC bit (see status bit)

OCP 17, 35, 39, 56

OPC bit (see status bit)

OPER bit (see status bit)

OT bit (see status bit)

output queue 27, 29, 32, 43, 51, 54, 57

OV bit (see status bit)

OVP 17, 18, 39, 42, 46, 64

overcurrent protection (see OCP)

overlapped commands 28, 57

overvoltage protection (see OVP)

P

parallel commands (see overlapped commands)	
programming	
accuracy (see Specifications in the User's Guide)	
examples	15-18, 55-56
parameters.....	46
resolution (see Supplemental Characteristics in the User's Guide)	
pending operations.....	16, 29, 33-35, 44, 57
PON bit (see status bit)	
power-on status (see "Chapter 5 - Front Panel Operation" in the User's Guide)	
primary address (see GPIB address)	
program message (see SCPI, command message)	
PSC bit (see status bit)	

Q

query	10, 12, 14, 15, 18
QUES bit (see status bit)	
QYE bit (see status bit)	

R

reading registers.....	18, 51, 53
real-time status.....	51
recalled parameters	30
recalling states	17, 30
reference documents	7-8
register commands	
status byte	32, 53
status operation	40, 51
status preset	42
status questionable.....	42, 53
standard event	27, 28, 53
remote inhibit (see RI)	
remote sense switch (see "Chapter 4 - User Connections' in the User's Guide)	
reset state (see *RST state)	
response message.....	10, 59
RI	
description of	53
digital connector, pins for (see "Appendix D - Digital Port Functions' in the User's Guide)	
Questionable Status bit (see status bit) signal electrical characteristics (see Table 1-5 in the User's Guide)	
root specifier.....	11, 12
RQS bit (see status bit)	
*RST state	31, 45, 46

S

saved parameters.....	31
saving states.....	17, 31
SCPI	
active header path	13
command tree	12, 34
common commands	10, 25-26
completed commands	57
confirmed commands.....	61
conformance	61
conventions.....	9
coupled commands	14
definition.....	9
documents.....	7-8
header (see SCPI header)	
message structure.....	12-13
message terminator	12
message unit.....	10
message unit separator.....	12
query indicator.....	12
related commands	25
root specifier	12
subsystem commands (see SCPI subsystem commands)	
version	44, 61
SCPI header	
conventions.....	12
long form	11
optional	13
path	13
separator	12
short form	11
serial poll	54
service request (see SRQ)	
SETUP.BAS	20
<SRD>.....	44
SRQ	32, 66
SCPI subsystem command	
ABOR.....	34
CURR	35
CURR:TRIG.....	35
CURR:PROT:STAT	35
DIG:DATA.....	36
DISP	36
DISP:MODE.....	37
DISP:TEXT	37
INIT	37
INIT:CONT	37
OUTP	37
OUTP:PROT:CLE.....	38
OUTP:PROT:DEL	39
OUTP:REL	39
OUTP:REL:POL	39

STAT:OPER?	40
STAT:OPER:COND?	40
STAT:OPER:ENAB	41
STAT:OPER:NTR	41
STAT:OPER:PTR	41
STAT:PRES	42
STAT:QUES?	42
STAT:QUES:COND?	42
STAT:QUES:ENAB	42
STAT:QUES:NTR	43
STAT:QUES:PTR	43
SYST:ERR?	43
SYST:LANG	44
SYST:VERS?	44
TRIG	44
TRIG:SOUR	45
VOLT	45
VOLT:TRIG	45
VOLT:PROT	46
status	
operation	40, 51
questionable	42, 53
standard event	27-28, 53
status bit	
CAL	40, 52
CC	40, 52
CME	27, 52
CV	40, 52
DDE	27, 52
ESB	27, 32, 52, 55
EXE	27, 52
MAV	27, 32, 52, 54
MSS	32, 52, 54
OC	35, 39, 42, 52, 56
OPC	27-29, 52, 57
OPER	32, 52, 56
OT	39, 42, 52, 56
OV	42, 46, 52
PON	27, 52, 55, 66
PSC	27, 29-30, 32, 53, 55
QUES	32, 52
QYE	27, 42, 52
RI	42, 52, 57
RQS	52, 54
UNR	42, 52
WTG	34, 42, 44, 52

T

TMSL	9, 44, 66
tree diagram	34
trigger	
continuous.....	37
immediate	33, 37
initiating.....	37
source.....	45
turn-on conditions (see "Chapter 5 - Front Panel Operation" in the User's Guide)	

U

units (see data, suffix)
UNR bit (see status bit)

V

value coupling (see SCPI, coupled commands)

W

wait state.....	33
WTG bit (see status bit)	

Agilent Sales and Support Office

For more information about Agilent Technologies test and measurement products, applications, services, and for a current sales office listing, visit our web site: <http://www.agilent.com/find/tmdir>

You can also contact one of the following centers and ask for a test and measurement sales representative.

United States:

Agilent Technologies
Test and Measurement Call Center
P.O. Box 4026
Englewood, CO 80155-4026
(tel) 1 800 452 4844

Latin America:

Agilent Technologies
Latin American Region Headquarters
5200 Blue Lagoon Drive, Suite #950
Miami, Florida 33126
U.S.A.
(tel) (305) 267 4245
(fax) (305) 267 4286

Canada:

Agilent Technologies Canada Inc.
5150 Spectrum Way
Mississauga, Ontario
L4W 5G1
(tel) 1 877 894 4414

Australia/New Zealand:

Agilent Technologies Australia Pty Ltd
347 Burwood Highway
Forest Hill, Victoria 3131
(tel) 1-800 629 485 (Australia)
(fax) (61 3) 9272 0749
(tel) 0 800 738 378 (New Zealand)
(fax) (64 4) 802 6881

Europe:

Agilent Technologies
Test & Measurement European Marketing Organisation
P.O. Box 999
1180 AZ Amstelveen
The Netherlands
(tel) (31 20) 547 9999

Asia Pacific:

Agilent Technologies
24/F, Cityplaza One, 1111 King's Road,
Taikoo Shing, Hong Kong
tel: (852)-3197-7777
fax: (852)-2506-9284

Japan:

Agilent Technologies Japan Ltd.
Measurement Assistance Center
9-1, Takakura-Cho, Hachioji-Shi,
Tokyo 192-8510, Japan
(tel) (81) 426 56 7832
(fax) (81) 426 56 7840
Technical data is subject to change.

Manual Updates

The following updates have been made to this manual since the print revision indicated on the title page.

4/1/00

All references to HP have been changed to Agilent.

All references to HP-IB have been changed to GPIB.

Information about installing instrument drivers has been added to chapter 1.